



Dry-type transformers

Safe and ecological
HiDry⁷²: dry-type transformers for
subtransmission (up to 72.5 kV / 63 MVA)

ABB dry-type transformers reaching 72.5 kV operating voltage and 63 MVA rated power

Traditionally, dry-type transformers have been used for distribution and industrial applications with rated power and voltage not higher than 15 MVA and 36 kV. Although ratings were increased steadily up to 40 MVA the limitation in voltage remained.

After intensive developments and responding to the demands of utility and industrial customers, ABB introduced in the nineties dry-type transformers for the 52 kV voltage class. The transformers met the 250 kV impulse test requirement and have proved highly reliable in a number of utility and industrial installations.

Several world-wide trends, like growing urbanisation and increased environmental awareness, have motivated ABB to take another innovative step, to take the dry-type transformer technology one stage further, and offer a product, named HiDry⁷², for the 72.5 kV voltage class. Dry-type transformers are therefore now also available for subtransmission applications. At the same time ABB have also succeeded in extending the rated power to 63 MVA.

The special features of ABB's subtransmission dry-type transformers are superior safety and environmental friendliness. This makes them especially suitable for applications such as inner-city substations, power plants, substations in or close to buildings or caverns, in water protection areas and for industrial applications, such as the chemicals, oil & gas industries.



Why choose a dry-type transformer for high voltage and large power?

HiDry⁷² offers the same advantages which you get with any ABB dry-type transformer: highest safety for people, property and the environment.

ABB dry-type transformers do not contain any flammable or explosive liquids. In the event of a fire the insulating materials in an ABB dry-type transformer are self-extinguishing. This greatly reduces the risk of smoke or fire damage to persons or property. This allows installing the transformers inside or very close to buildings. Because HiDry⁷² allows higher voltages to be safely installed closer to the load centre, energy losses are reduced at the distribution voltage level.

Thanks to the dry-type technology there is no risk of soil or water contamination due to transformer liquid spills. This makes HiDry⁷² especially suitable for installations in environmentally sensitive or seismic areas and eliminates the need for oil-pits, civil work, fire protection walls and other protective equipment.

HiDry⁷² offers the same functionalities as liquid-immersed transformers. It is suitable for new or for retrofit installations, Y- or D-connected, and can be used indoors and with an enclosure for outdoor applications. ABB dry-type transformers offer the highest level of short circuit strength and require a minimum of maintenance.

When choosing dry-type transformers you will find significant cost savings:

- less civil works
- no fire extinguishing systems
- reduced insurance fees
- no need for erection on site
- shorter cable runs
- reduced maintenance

1 Civil works | 2 Fire systems and insurance fees | 3 Site installation and shorter cables | 4 Maintenance

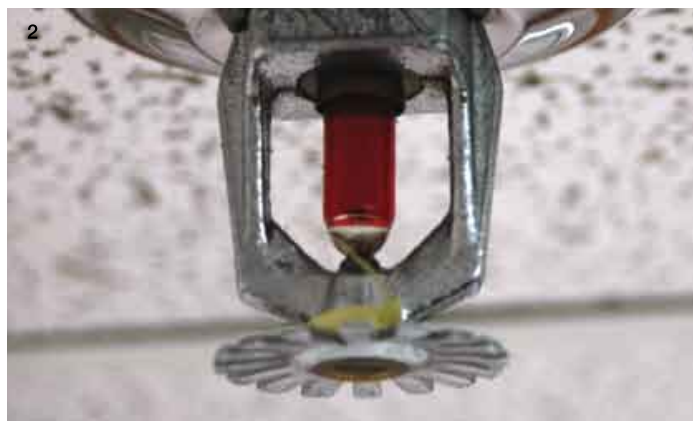

Which are the typical applications for HiDry⁷²?

Fast growth of cities along with a strongly increasing demand for electric power supply continues. Many cities encounter bottlenecks in supplying their downtown load centers by means of the traditional distribution voltage level. HiDry⁷² allows for a significant increase in the infeed power while at the same time reducing safety risks.

Modern HVAC systems, advanced lighting systems and IT networks are all requesting increasingly reliable power in our hospitals, shopping malls, skyscrapers, multipurpose cultural centres and sports stadiums. Because of the growing size of these buildings the power requirements are also increasing. Traditionally, dry-type transformers are installed in basements or in adjacent buildings due to increased safety requirements. Such buildings can now be served directly at subtransmission voltage and with higher power ratings.

Electric power plants and other public utilities require high reliability and safety for their installations. Dropouts can effect a large amount of people and have serious consequences. The same is valid for industrial applications, especially in the field of chemicals, oil and gas.

Water and ground water protection areas, harbours and docks, forestry fire risk areas, or applications in the field of renewable energies can all benefit from the environmental advantages of HiDry⁷².

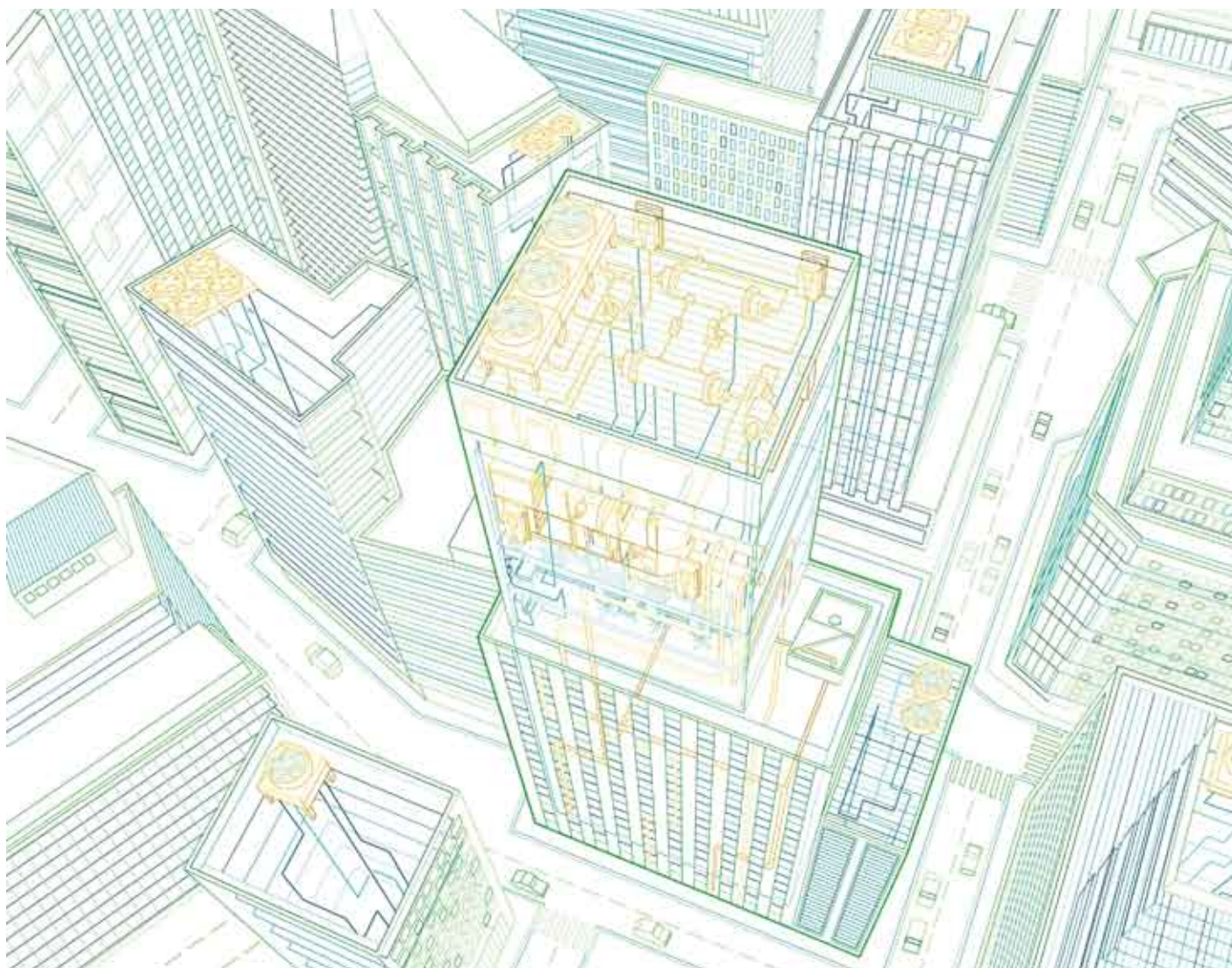

HiDry⁷² applications



HiDry⁷² technology and lightning impulse withstand voltage level up to 380 kV

HiDry⁷² fulfills the following dielectric test voltage level requirements:

Standard	LI (kV)	AC (kV)
IEC	325	140
IEEE	350	140
GOST	180	90

However, dry-type technology has been tested up to 380 kV/AC 155 kV.

The use of computer simulation modelling and experimental testing on prototype units has allowed ABB dry-type transformers to develop new concepts. This has led to advances in our compact insulation configuration using air and solid materials. The use of F and H class insulation materials, with a high temperature difference to the ambient air, allows efficient transformer cooling.

Voltage distribution along windings for 325 kV lightning impulse test

Maximum values (kV)

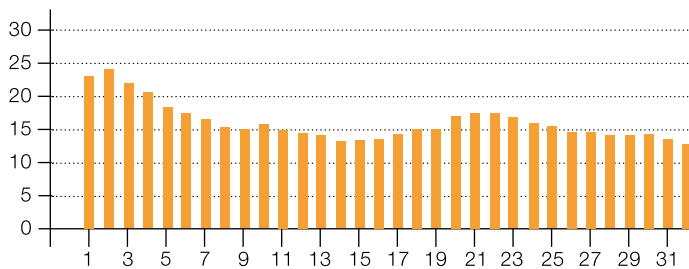

Partial discharge measurements, well below the 10pC limit for dry-transformers, show that the insulation materials and overall transformer finishing are of a very high quality. ABB dry-type transformers have been tested well beyond their limits to guarantee a large safety margin and customer peace of mind.

Detailed engineering analysis (design modelling, based on FEM-finite elements model) enables our designers to accurately know the voltage distribution inside the winding during lightning impulse testing. The increased demands of the 72.5 kV series transformer design require special manufacturing solutions, such as improved performance high voltage terminals, strengthened insulation, rounded decks, larger clearances and special supports to increase the creepage distances.

Temporal behavior of voltage distribution during application of lightning impulse

- 33 - 2 : 23.1 @ 1.0 usec
- 2 - 3 : 24.1 @ 1.3 usec
- 3 - 4 : 21.8 @ 1.3 usec
- 4 - 5 : 20.7 @ 1.5 usec

Actual voltage (kV)

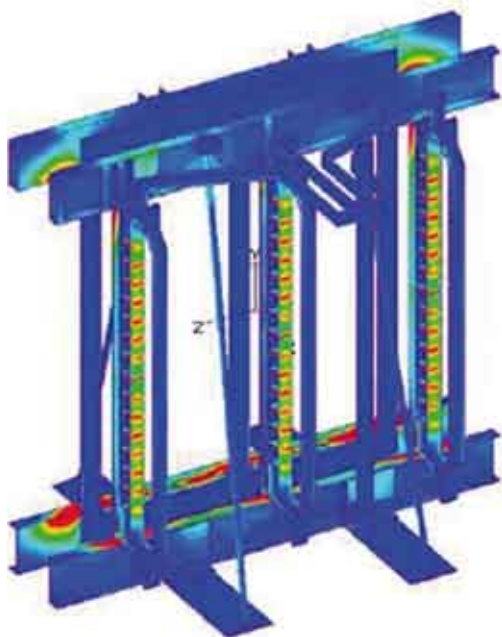
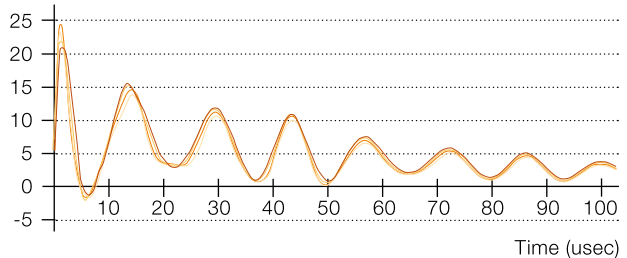

Calculation of losses in structural components.

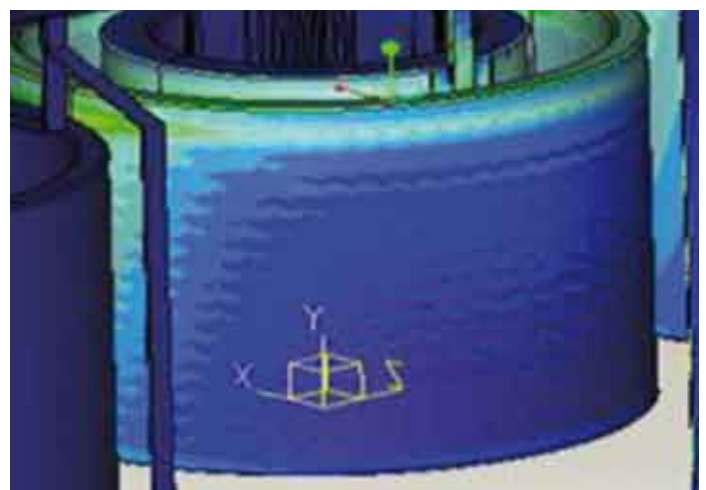

Electric field calculations.

Our portfolio: all kind of customized designs

All kind of customised designs

- Special and tailored design
- Transformers for both indoor and outdoor installations
- Reduced loss transformers
- Transformers with tertiary winding for auxiliary services
- Insulation material class F or H
- Variable speed drives (VSD) application
- Step-up transformer
- Multiple high voltage inputs
- Air gap core
- Earthing screen

Other accessories

- On-load tap changer with up to 23 positions, motor drive and automatic voltage regulator (AVR) and lamp board indicator
- Antivibration pads
- Space heaters
- Cooling fans allowing up to 25% power increase
- Special high voltage connections
- High voltage surge arresters
- Plug in bushings on high voltage side
- High voltage isolated phase bus (IPB)
- Current transformers on high voltage side
- Earthing bullets
- Special accessories: upon customer request
- Bus duct on high voltage or low voltage, with flanges for coupling
- Metallic enclosure with protection degrees IP21, 23, 31, 33, 44, 54
- Enclosure with high voltage and low voltage cable boxes
- Air forced water forced IP54 enclosures with hydrocoolers
- Digital controller thermometer with Pt100 sensors (alarm, – tripping and fault switches, and software available)
- Digital controller thermometer including RS485 digital exit and 4÷20 mA analogical exit, with Pt100 sensors
- Pyrometer as temperature sensor
- Arc guard system



Contact us

ABB Management Service Ltd.

Affolternstrasse, 44

P.O. Box 8131

8050 Zurich, Switzerland

www.abb.com/transformers

Note:

We reserve the right to make technical changes or modify the contents of this document without prior notice. With regard to purchase orders, the agreed particulars shall prevail. ABB does not accept any responsibility whatsoever for potential errors or possible lack of information in this document.

We reserve all rights in this document and in the subject matter and illustrations contained therein. Any reproduction – in whole or in parts – is forbidden without ABB's prior written consent.

Copyright© 2011 ABB
All rights reserved.