

ABB Brand Identity, November 18, 2011

# ABB brochure concept

## Communicating with our revitalized identity

## Introduction

- 3 Worldwide recognition
- 4 Six essentials to revitalize our brand
- 5 The essentials at a glance

## Basics

- 6 Colors
- 11 Brochure categorization
- 12 Imagery

## Covers

- 16 Layout principles for covers
- 19 Titles on covers
- 21 Back covers

## Inside pages

- 23 Layout principles for images
  - The design grid
  - Sizing images
- 28 Layout principles for text
  - The 12-column grid
- 32 Typography – all levels
  - Type sizes and line spacing
  - Headline position and sizes
  - Headline alignment with text and images
  - Text hierarchies
  - Tables
  - Graphs

## Production guidance

- 44 Quality brochure reproduction
- 45 Appendix

## Worldwide recognition

The ABB brochure guidelines have been created for all ABB employees and partners who create and work with communications.

For any questions please e-mail maria.jobin@ch.abb.com or peter.stierli@ch.abb.com

### IMPORTANT

Re-use of images featured in these guidelines is strictly forbidden. Please use the contacts above to understand if the necessary usage licence exists, and to obtain the relevant source files.

**ABB is one of the world's leading power and automation groups, and one of the best known brands in its markets. Our power and automation businesses are in an excellent position to benefit from current and future developments in our industry and to thrive in a highly competitive environment.**

The way we communicate about our company and present ourselves to our stakeholders has a major influence on how we are perceived and rated by the outside world. A distinctive and consistent corporate design goes a long way toward generating long-term added value for the ABB brand. By setting ourselves apart from our competitors, we strengthen our position in the market. Our newly sharpened identity will have a substantial role to play in achieving this distinction. It will give ABB a unique, dynamic and emotionally appealing face reflecting our clear market position.

**ABB delivers efficient solutions for a dynamic world. ABB builds and maintains a dynamic sphere of power and productivity – 24/7 around the world.**

Brochures are an important medium of communication for ABB. These guidelines describe how we will achieve a consistent identity across our organization, creating a clear brochure system for our diverse communication needs.

Please use these guidelines in conjunction with the basic elements and the guidelines for specific applications.

## Six essentials to revitalize our brand



**1. ABB is the brand**  
One company, one brand



**2. The world of ABB is built on black and white**  
Day and night, 24/7, across the globe

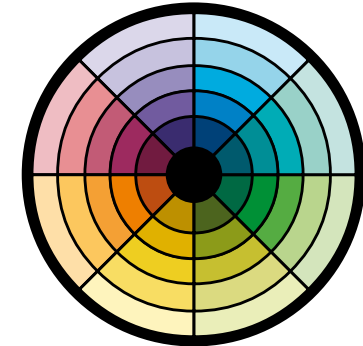

**3. The color of ABB is bright**  
Attractive and multi-faceted

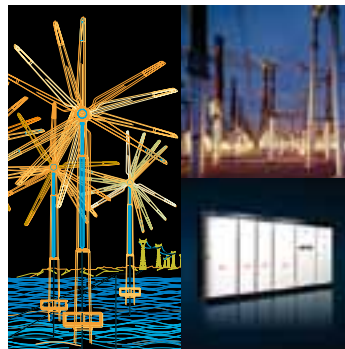

**4. Our images reflect leading-edge technology**  
Emanating light and dynamic motion



**5. Neue Helvetica is our typeface**  
Systematic and precise

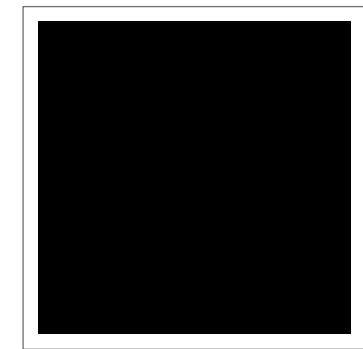

**6. A white frame captures our content**  
Focused and inclusive

## The essentials at a glance

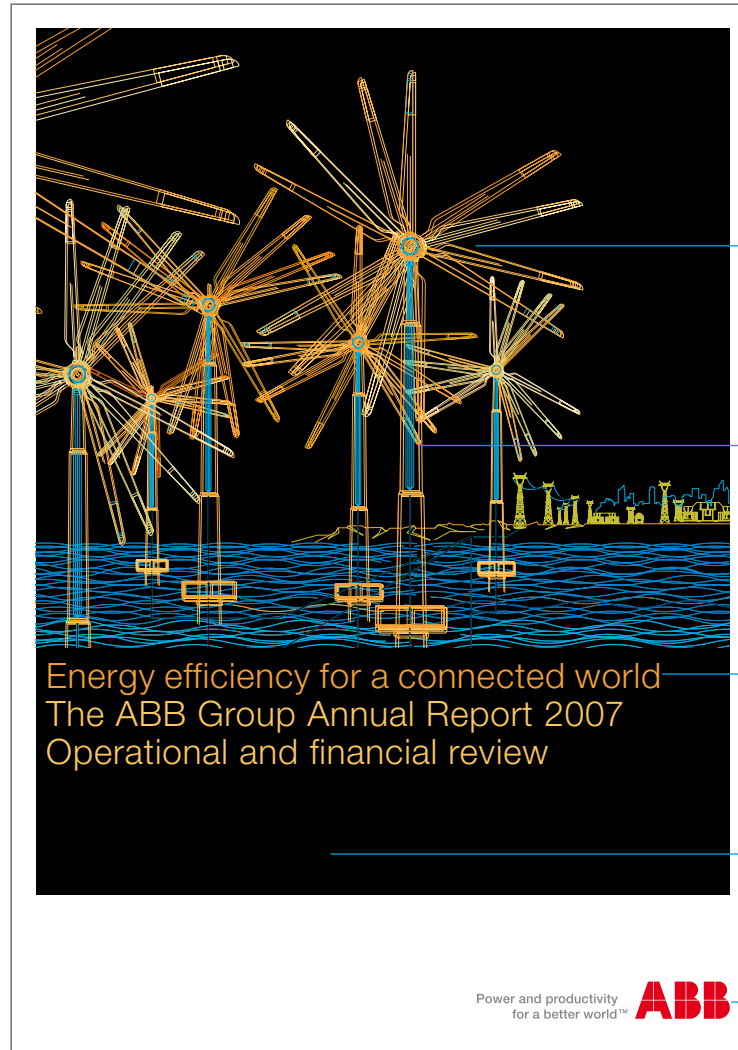

### A white frame captures our content

Focused and inclusive

### Our images reflect leading-edge technology

Emanating light and dynamic motion

### The color of ABB is bright

Attractive and multi-faceted

### Neue Helvetica is our typeface

Systematic and precise

### The world of ABB is built on black and white

Day and night, 24/7, across the globe

### ABB is the brand

One company, one brand

# Color for images on covers

Primary colors used for our logo and background are white, black and red as defined in the basic elements guidelines.

Secondary colors, used for imagery and text, have been chosen to reflect the dynamism of ABB. These are based on a color circle divided into segments as shown opposite.

### Illustrations

Colors used in fine-line illustrations must be selected from the segmented color wheel shown opposite. Two segments are selected, and the colors therein (circles 1-5) used as the predominant colorways throughout the illustration. Small quantities of color may be selected from outside of these segments for highlighting effect, detailing and/or adding visual richness - as needed.

Fine-line illustrations on a black background are used for brochure covers only **1 2**.

### Photography

“First level photography” (see page 5 of imagery guidelines for definition) can feature colors that naturally occur in the shot **3**, or may be amended in post production to reflect two predominant color segments as shown opposite **4**.



**3** Natural colors



**4** Colors from segments A and B

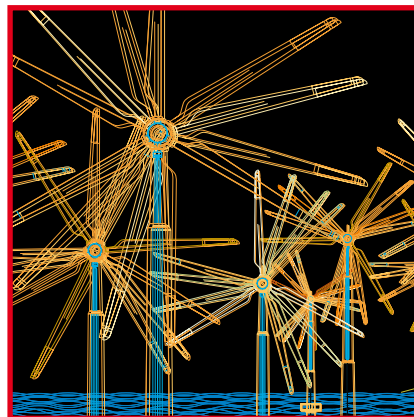

**2** Colors from segments A and B



**1** Colors from segments A and D

## Color for images on inside pages

### Illustrations

Fine-line illustrations are used on a white background for all inside pages of brochures **1**. Always ensure vibrant color combinations and strong stand-out against the background color used.

### NB Photography

All photography used on inside pages is “second level photography” as described on page 5 of the imagery guidelines. The colors therein are naturally occurring – and so are not determined by the color wheel. All images are bright and light and are used on a white background **2**.

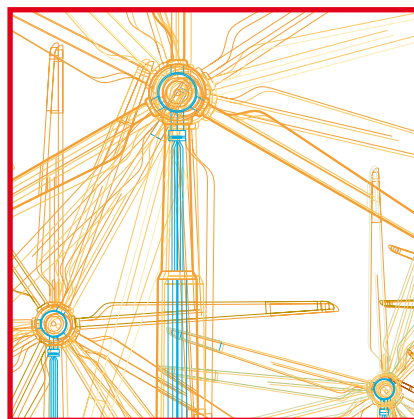
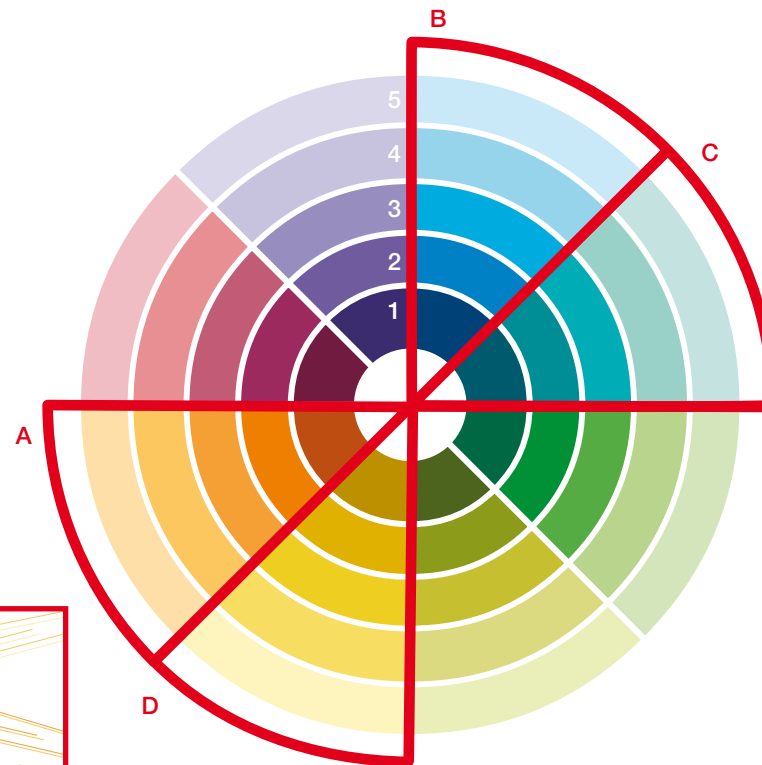

**1** Colors from segments A and B



**2** NB The colors within second level photography - as used on the inside pages of brochures - are not determined by the color wheel. See explanation opposite.

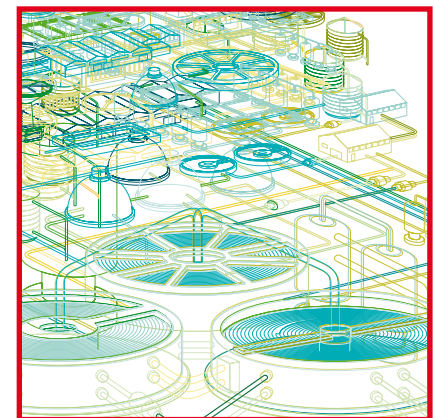

**1** Colors from segments C and D

# Color for text

## Cover titles

Take one of the predominant color segments chosen for the imagery. Use the colors featured in circles 3 and 4 for all typography on a black background. Always start the cover title with the darker color (circle 3) and subtitles with the lighter color (circle 4) **1**.  
 When natural color photography is used select the color segment that best matches the colors of the pictures **2**.

## Inside page headlines

The color segments used for cover titles continue on inside pages throughout the brochure. Use the colors featured in circles 1 and 2 of the respective color segment for all colored typography **3**.

Note that in larger brochures, to differentiate chapters, more colors may be chosen from circles 1 and 2 from around the color circle. To choose these colors, move clockwise round the color circle, starting with the segment that follows the color selected for the cover image. Note that no color changes are allowed within a chapter.

## Body text on inside pages

Body text may also be colored for special use as follows:  
 Colored text for highlighting purpose – used across all levels; see pages 37–39 for full details. The color segment chosen for the headline of the chapter is also used on inside pages for highlighting text using circles 1 and 2 within that segment.



**2** Cover title: color I and J

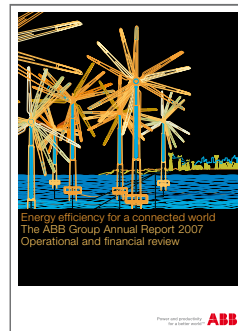

**1** Cover title color A and B



**3** Inside headline: color C and D  
 Body text: color C

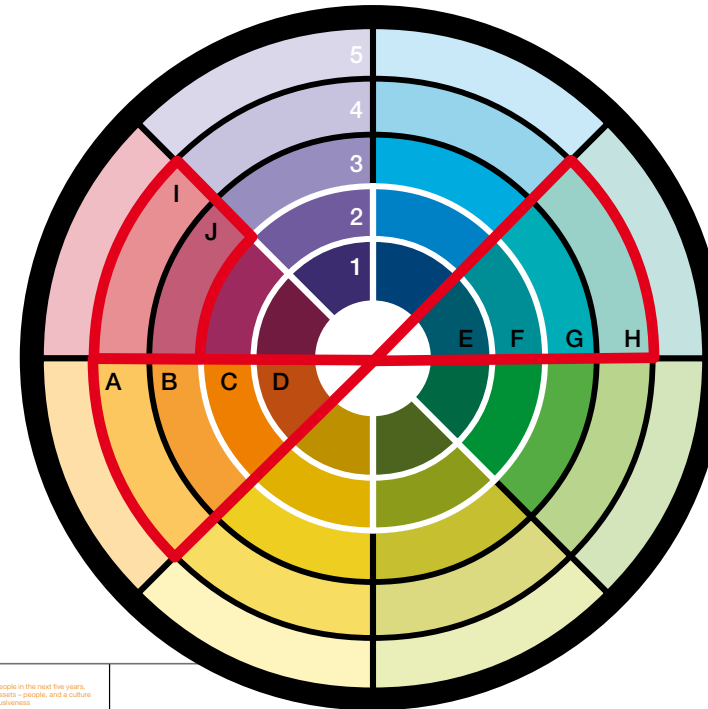

**1** Cover title: color G and H



**3** Inside headline: color E and F  
 Intro text: color F

# Color for charts, diagrams and graphs

Colors selected for these follow the predominant color segment chosen for the imagery on the cover. All colors within that segment may be used (circles 1–5). If further colors are needed, take the colors of the second color segment selected for imagery on the cover.

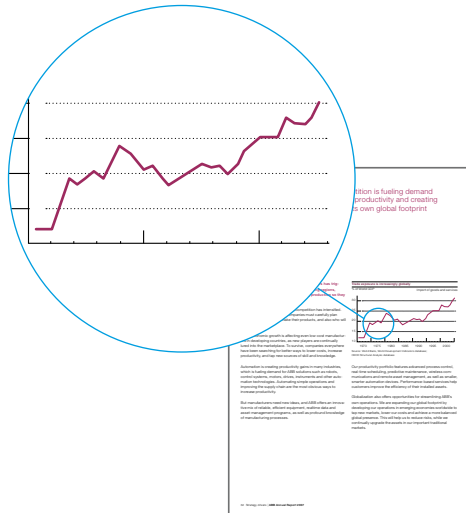

Color segment A

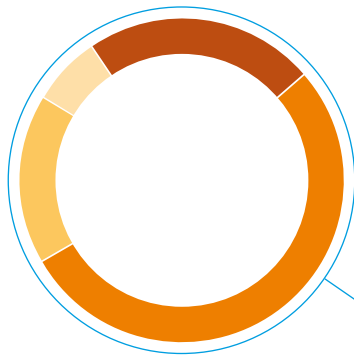

Color segment B

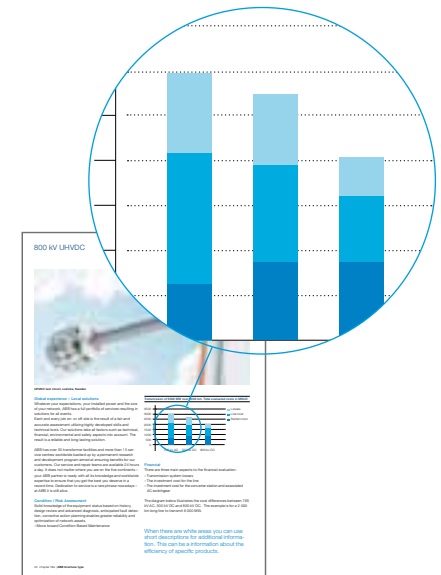
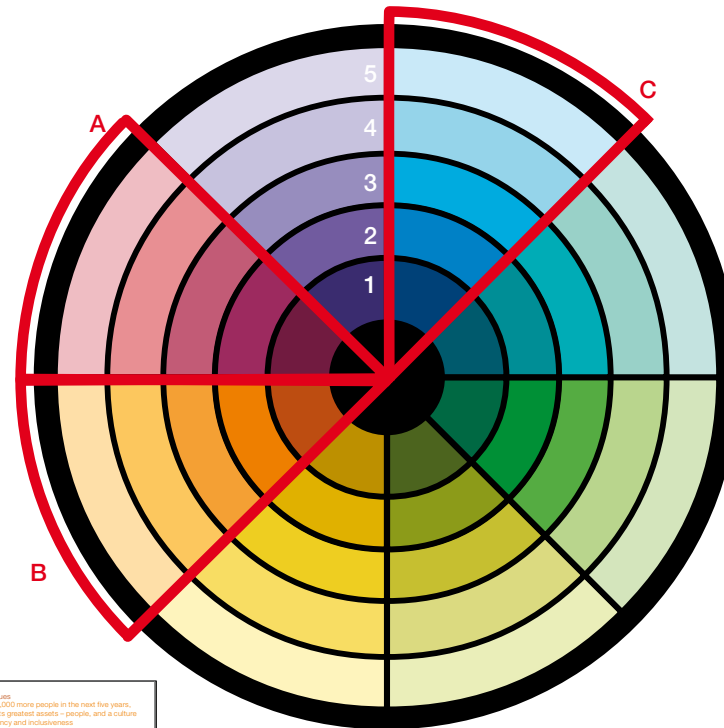

Color segment C

## Color specifications

### Primary colors

#### ABB Red

Pantone 032 C  
Pantone 032 U  
CMYK 0/100/100/0  
RGB 255/0/15  
WebHex FF 00 0F  
RAL 3020  
HKS 13 K  
Scotchcal 100-13

#### ABB Gray

Pantone Cool Gray 8 C  
Pantone Cool Gray 8 U  
CMYK 0/0/0/60  
RGB 134/134/134  
WebHex 99 99 99  
RAL 7045  
HKS 92 N  
Scotchcal 100-038

#### Black

Pantone Process K C  
Pantone Process K U  
CMYK 50/45/45/100  
RGB 0/0/0  
WebHex 00 00 00  
RAL 9004  
HKS 88 K  
Scotchcal 100-12

#### White

Pantone White C  
Pantone White U  
CMYK 0/0/0/0  
RGB 255/255/255  
WebHex FF FF FF  
RAL 9003  
HKS White  
Scotchcal 100-10

Please see below.

### Important information for printing CMYK

1. The density value for black, measured on the wet printed sheet, should be DV 1.75 to DV 1.80. Tolerance +/- 0.03
2. The order of colors for CMYK print is black, cyan, magenta and yellow.

### Secondary colors

#### Blue

Pantone 2945 C  
CMYK 100/60/0/40  
RGB 0/75/122  
WebHex 00 4B 7A  
RAL 250 40 30  
HKS 41 N

ABB\_B\_Head-W

#### Blue-green

Pantone 3155 C  
CMYK 100/0/25/55  
RGB 0/85/95  
WebHex 00 55 5F  
RAL 210 40 38  
HKS 59 N

ABB\_BG\_Head-W

#### Green

Pantone 356 C  
CMYK 90/0/75/45  
RGB 0/85/20  
WebHex 00 55 14  
RAL 150 40 50  
HKS 58 N

ABB\_G\_Head-W

#### Green-yellow

Pantone 378 C  
CMYK 65/30/100/40  
RGB 78/86/29  
WebHex 4E 56 1D  
RAL 100 40 40  
HKS 61 N

ABB\_GY\_Head-W

#### Yellow

Pantone 1255 C  
CMYK 15/35/100/25  
RGB 175/120/1  
WebHex AF 78 01  
RAL 080 60 50  
HKS 74 N

ABB\_Y\_Head-W

#### Orange

Pantone 1525 C  
CMYK 0/75/100/25  
RGB 154/40/1  
WebHex 9A 28 00  
RAL 050 50 70  
HKS 83 N

ABB\_O\_Head-W

#### Orange-violet

Pantone 235 C  
CMYK 55/100/55/25  
RGB 109/21/65  
WebHex 6D 15 41  
RAL 350 30 40  
HKS 18 N

ABB\_OV\_Head-W

#### Violet

Pantone 7447 C  
CMYK 85/90/5/25  
RGB 73/56/129  
WebHex 49 38 81  
RAL 300 30 30  
HKS 35 N

ABB\_V\_Head-W

### Headline on white

### Subheadline on white

### Headline on black

### Subheadline on black

### Additional colors

Pantone 3005 C  
CMYK 100/30/0/0  
RGB 0/118/183  
WebHex 00 76 B7  
RAL 250 50 40  
HKS 47 N

ABB\_B\_Sub-W

Pantone 321 C  
CMYK 100/0/40/10  
RGB 0/121/135  
WebHex 00 79 87  
RAL 200 50 45  
HKS 59 N, 90%

ABB\_BG\_Sub-W

Pantone 361 C  
CMYK 100/0/100/0  
RGB 2/130/8  
WebHex 02 82 08  
RAL 130 60 60  
HKS 58 N, 90%

ABB\_G\_Sub-W

Pantone 384 C  
CMYK 50/20/100/10  
RGB 106/116/0  
WebHex 6A 74 00  
RAL 100 60 60  
HKS 62 N

ABB\_GY\_Sub-W

Pantone 110 C  
CMYK 15/30/100/0  
RGB 221/160/10  
WebHex DD A0 0A  
RAL 085 70 75  
HKS 73 N, 85%

ABB\_Y\_Sub-W

Pantone 152 C  
CMYK 0/60/100/0  
RGB 191/69/0  
WebHex BF 45 00  
RAL 060 60 80  
HKS 81 N

ABB\_O\_Sub-W

Pantone 215 C  
CMYK 45/95/40/0  
RGB 176/74/116  
WebHex B0 4A 74  
RAL 360 40 50  
HKS 18 N, 80%

ABB\_OV\_Sub-W

Pantone 2725 C  
CMYK 76/74/5/0  
RGB 110/90/161  
WebHex 6E 5A A1  
RAL 290 50 40  
HKS 35 N, 85%

ABB\_V\_Sub-W

Pantone 2995 C  
CMYK 80/0/30/0  
RGB 0/150/234  
WebHex 00 96 EA  
RAL 230 60 40  
HKS 47 N, 80%

ABB\_B\_Head-B

Pantone 326 C  
CMYK 80/0/30/0  
RGB 0/172/182  
WebHex 00 AC B6  
RAL 190 60 45  
HKS 59 N, 80%

ABB\_BG\_Head-B

Pantone 375 C  
CMYK 70/0/90/0  
RGB 58/178/0  
WebHex 3A B2 00  
RAL 120 70 75  
HKS 58 N, 70%

ABB\_G\_Head-B

Pantone 397 C  
CMYK 30/15/90/0  
RGB 176/176/35  
WebHex B0 B0 23  
RAL 095 80 80  
HKS 62 N, 80%

ABB\_GY\_Head-B

Pantone 7405 C  
CMYK 10/15/90/0  
RGB 238/206/35  
WebHex EE CE 23  
RAL 090 80 90  
HKS 04 N

ABB\_Y\_Head-B

Pantone 137 C  
CMYK 0/45/85/0  
RGB 255/108/0  
WebHex FF 6C 03  
RAL 070 70 80  
HKS 07 N

ABB\_O\_Head-B

Pantone 702 C  
CMYK 25/75/35/0  
RGB 218/61/99  
WebHex DA 3D 63  
RAL 020 60 40  
HKS 18 N, 70%

ABB\_OV\_Head-B

Pantone 7446 C  
CMYK 47/47/0/0  
RGB 152/104/239  
WebHex 98 68 EF  
RAL 290 60 35  
HKS 35 N, 60%

ABB\_V\_Head-B

Pantone 2905 C  
CMYK 45/0/5/0  
RGB 91/216/255  
WebHex 5B D8 FF  
RAL 230 80 20  
HKS 47 N, 50%

ABB\_B\_Sub-B

Pantone 324 C  
CMYK 45/0/25/0  
RGB 57/232/218  
WebHex 39 E8 DA  
RAL 190 80 20  
HKS 59 N, 50%

ABB\_BG\_Sub-B

Pantone 366 C  
CMYK 35/0/55/0  
RGB 152/219/56  
WebHex 98 DB 38  
RAL 120 80 40  
HKS 58 N, 40%

ABB\_G\_Sub-B

Pantone 585 C  
CMYK 20/5/60/0  
RGB 198/213/94  
WebHex C6 D5 5E  
RAL 110 90 40  
HKS 62 N, 50%

ABB\_GY\_Sub-B

Pantone 602 C  
CMYK 5/5/50/0  
RGB 244/238/127  
WebHex F4 EE 7F  
RAL 100 90 50  
HKS 04 N, 50%

ABB\_Y\_Sub-B

Pantone 134 C  
CMYK 0/25/70/0  
RGB 253/172/37  
WebHex FD AC 25  
RAL 080 80 50  
HKS 07 N 70%

ABB\_O\_Sub-B

Pantone 700 C  
CMYK 5/55/30/0  
RGB 230/155/180  
WebHex E6 9B B4  
RAL 020 80 20  
HKS 18 N, 50%

ABB\_OV\_Sub-B

Pantone 7444 C  
CMYK 25/25/0/0  
RGB 180/160/232  
WebHex B4 A0 E8  
RAL 280 70 20  
HKS 35 N, 30%

ABB\_V\_Sub-B

Pantone 2905 C, 60%  
CMYK 25/0/0/0  
RGB 172/236/255  
WebHex AC EC FF  
RAL 230 80 20, 60%  
HKS 47 N 20%

ABB\_B\_lightest

Pantone 324 C, 60%  
CMYK 28/0/14/0  
RGB 151/255/239  
WebHex 97 FF EF  
RAL 190 80 20, 60%  
HKS 59 N, 30%

ABB\_BG\_lightest

Pantone 366 C, 60%  
CMYK 22/0/34/0  
RGB 199/252/166  
WebHex C7 FC A6  
RAL 120 80 40, 60%  
HKS 58 N, 20%

ABB\_G\_lightest

Pantone 585 C, 60%  
CMYK 12/0/36/0  
RGB 224/235/146  
WebHex E0 EB 92  
RAL 110 90 40, 60%  
HKS 62 N, 20%

ABB\_GY\_lightest

Pantone 602 C, 60%  
CMYK 2/2/34/0  
RGB 250/243/174  
WebHex FA F3 AE  
RAL 100 90 50, 60%  
HKS 04 N, 30%

ABB\_Y\_lightest

Pantone 134 C, 60%  
CMYK 0/15/40/0  
RGB 255/219/133  
WebHex FF DB 85  
RAL 080 80 50, 60%  
HKS 07 N 40%

ABB\_O\_lightest

Pantone 700 C, 60%  
CMYK 4/34/14/0  
RGB 241/190/197  
WebHex F1 BE C5  
RAL 020 80 10, 60%  
HKS 18 N, 30%

ABB\_OV\_lightest

Pantone 7444 C, 60%  
CMYK 16/16/0/0  
RGB 216/204/248  
WebHex D8 CC F8  
RAL 280 70 20, 60%  
HKS 35 N, 20%

ABB\_V\_lightest

## Brochure categorization

ABB brochures are categorized as follows:

**Corporate image level**  
 (Level 1)

**Information level**  
 (Levels 2.1 and 2.2)

**Instruction level**  
 (Level 3)

This simple categorization is fundamental to the use of these guidelines.

Suggested application lists for each of these categories are shown opposite.

Illustration/  
typography

### 1 Corporate image level

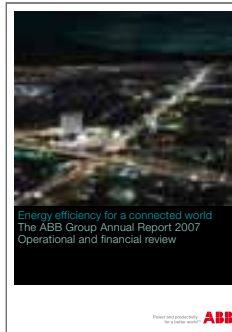
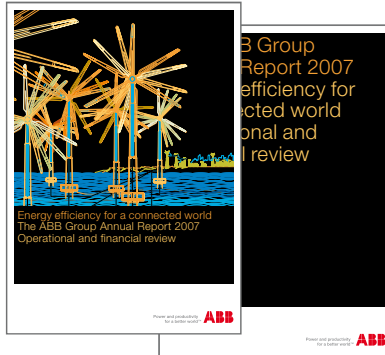

Photography

- Annual report
- Image brochure
- Corporate brochure
- etc.

### 2.1 Information level

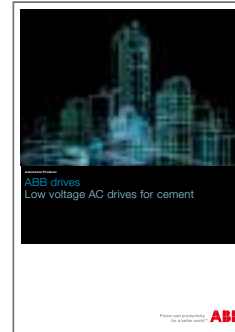

Suggested use:

- Division brochure
- Business unit brochure
- Business unit overview
- System group brochure
- Product group brochure
- Product service brochure
- Segment brochure
- etc.

### 2.2 Information level

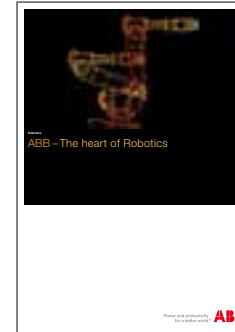

Suggested use:

- Product brochure (single product)

### 3 Instruction level



Suggested use:

- Product leaflet
- Data sheet
- Product guide
- Product manual
- Technical datasheet
- Success stories
- Reference lists
- etc.

# Imagery – Corporate image level 1

At corporate image level, fine-line illustrations are featured on a black background; or photography is used with a dark-colored background as part of the shot. These images are referred to as “first level imagery” in the imagery guidelines.

“First level imagery” is used only on covers.

All inside pages feature the light/bright images explained in the imagery guidelines as “second level imagery”.

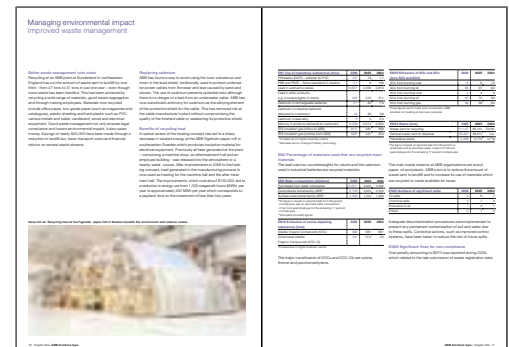
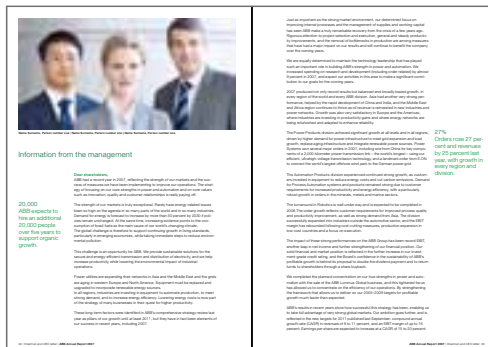
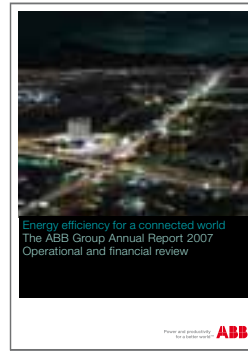
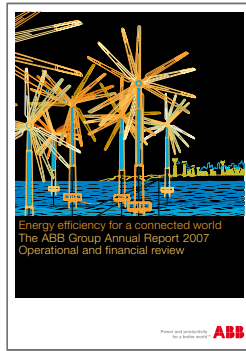

# Imagery – Information levels 2.1 and 2.2

Information level brochures also feature “first level imagery” on covers. These images are used in a different size format to those used at corporate image level.

All inside pages must feature the light/bright images explained in the imagery guidelines as “second level imagery”.

“First level imagery” is not permitted for inside page use at information level.

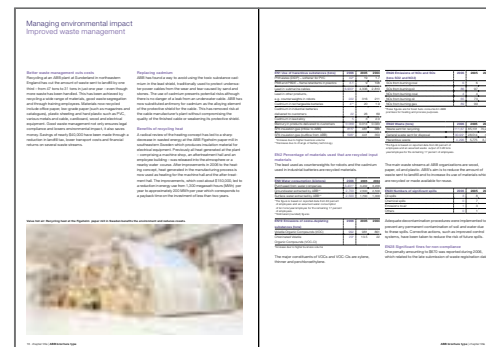
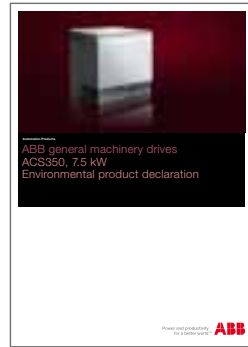
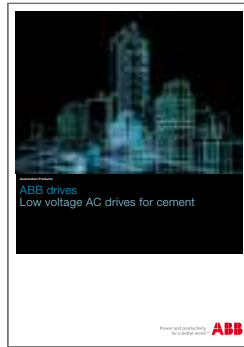

## Imagery – Instruction level 3

Instruction level brochures use “second level imagery” only.

The cover uses a headline area, in conjunction with body text.

Any images featured must be placed within the text area and must be bright/light as defined in the imagery guidelines.

Products and/or objects must feature a mirror effect as defined in the imagery guidelines.

Technical drawings are also generally acceptable when drawn in black and white, with a spot color used to highlight an important feature or detail.

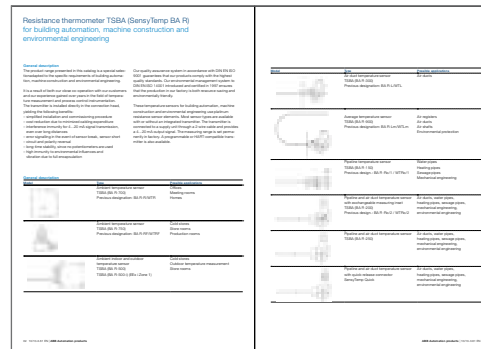



The ABB Group  
Annual Report  
Energy efficiency  
a connected world  
Operational and  
financial review



## White frame and logo position

The white frame captures our world and our message, and focuses our audience. This is featured in all media.

Dimensions for brochures are defined as follows:

### ■ A4 and larger sizes

The width of the white frame is  $\frac{1}{30}$  th = x of the short side of the page.

**ABB Logo size:** 1.5x

**Position:** 1.5x from the bottom edge of the page. Positioned right.

### ■ Formats smaller than A4

The width of the white frame is 7 mm.

**ABB Logo size:** 7 mm

**Position:** 7 mm from the bottom edge of the page. Positioned right.

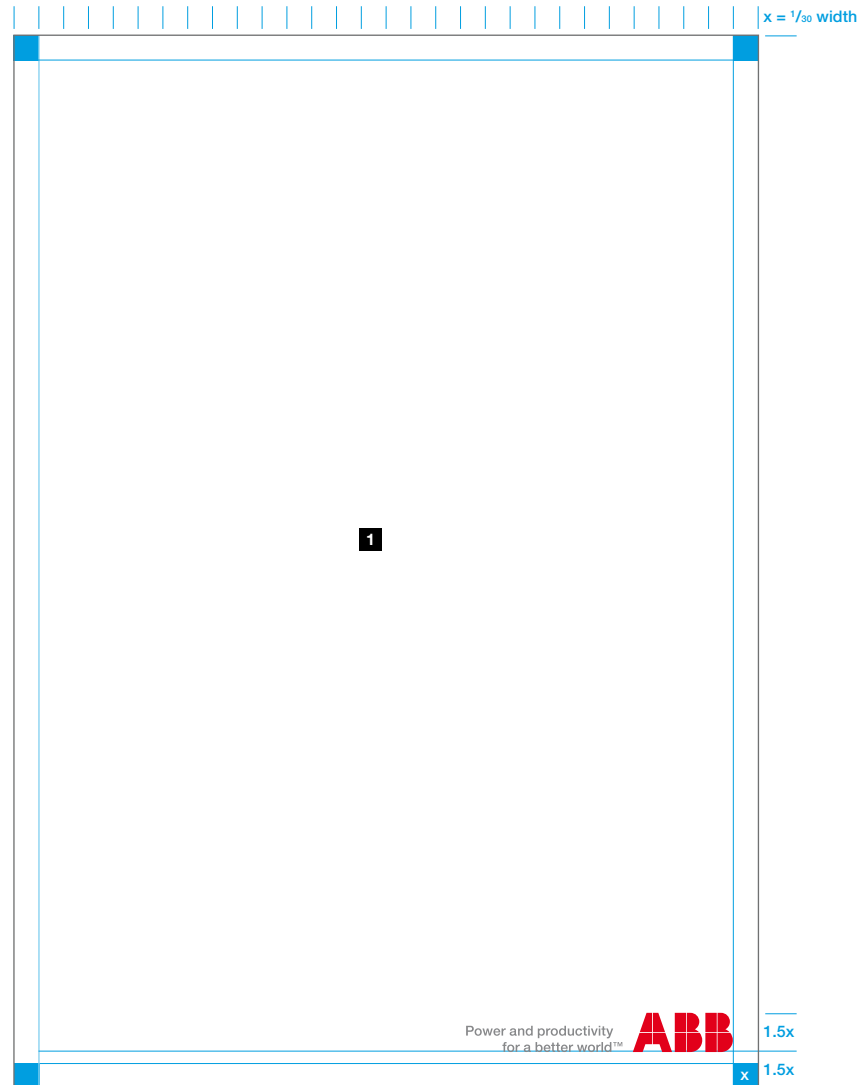

A4 and larger sizes

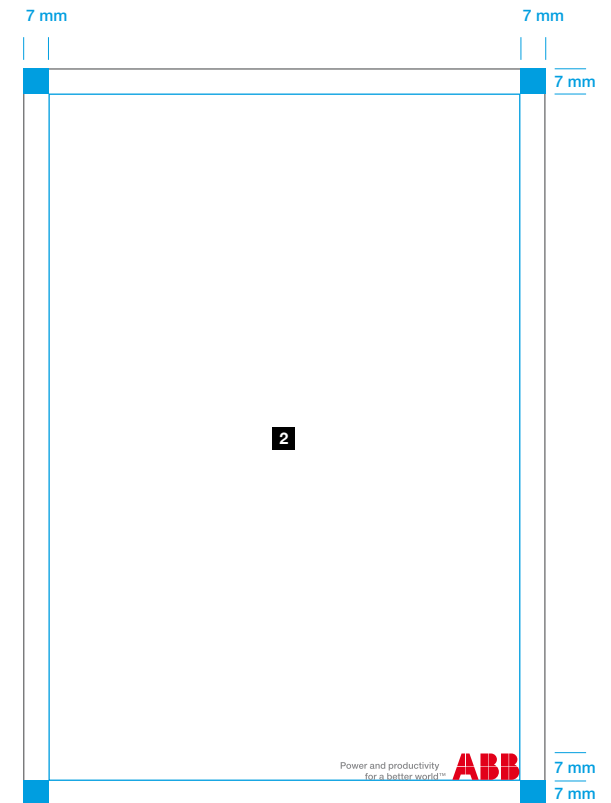

A4 and smaller sizes

## White frame sizes for cover pages

### A4 and larger sizes

The width of the white frame is  $\frac{1}{30}$  th = x of the short side of the page.

### ABB Logo size: 1.5x

**Position:** 1.5x from the bottom edge of the page.

### Formats smaller than A4

The width of the white frame is always 7 mm.

### ABB Logo size: 7 mm

**Position:** 7 mm from the bottom edge of the page.

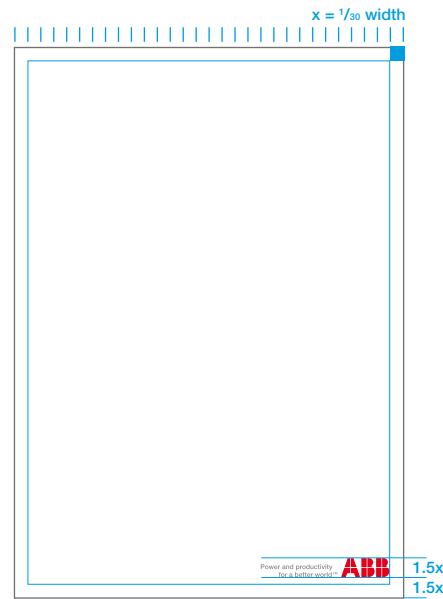

A3

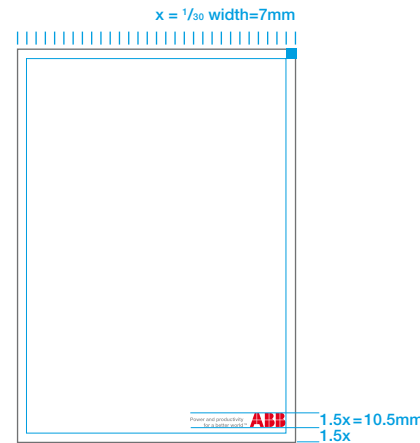

A4

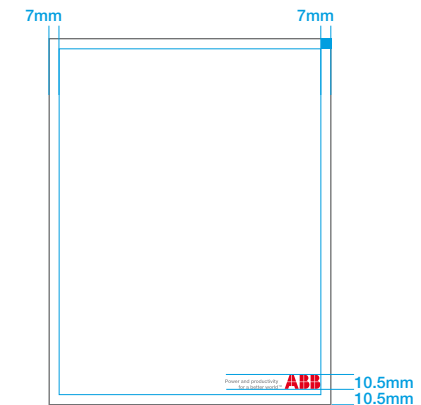

U.S. letter

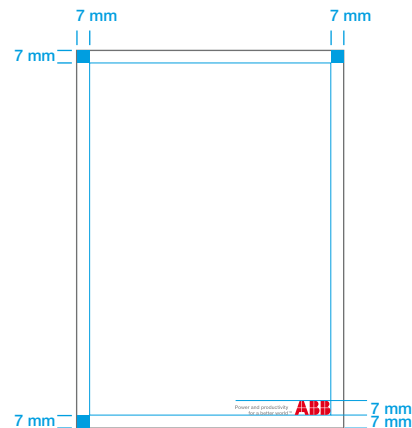

A5

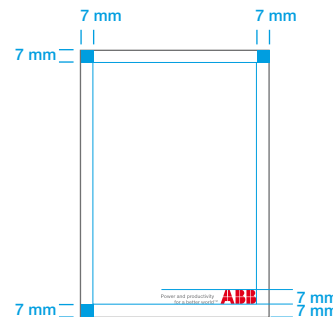

A6



A6/5

## Primary grid for cover pages

### Grid

The primary grid is used for the front cover of all publications, advertising and initial electronic media screens. The grid is the area within the white frame and is divided into eight horizontal parts of equal size.

### Logo area

Area 8 is reserved for the ABB logo. The size and position are clearly defined (see pages 16–17).

### Design area

The design space reaches from section 1 to 7 and is divided into an image area (shown in gray) and a text area (shown in black). The image area must always be bigger than the text area (except at instruction level).

### Landscape format

The same principle applies to landscape formats. Landscape formats are possible at corporate image level only.

### ! Exception A6/5 landscape

Area 8 is usually reserved for the ABB logo. In this small format area 8 and an additional half of area 7 are used to accommodate the ABB logo. The black text area therefore moves up by half too.

### 1 Corporate image level



At corporate image level 1, the design space uses 7 parts. The image area occupies 5 parts and the text area 2 parts.

### Exception: A6/5 landscape

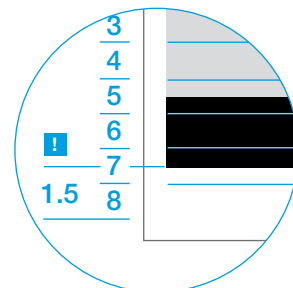
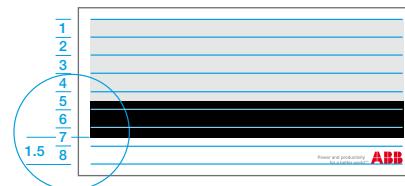

### 2.1 Information level



At information level 2.1, the design space uses 6 parts. The image area occupies 4 parts and the text area 2 parts.

### 2.2 Information level

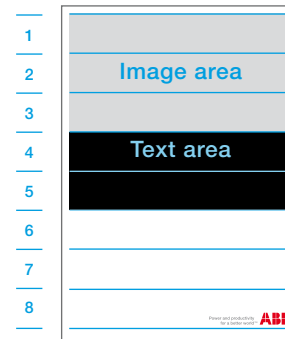

At information level 2.2, the design space uses 5 parts. The image area occupies 3 parts and the text area 2 parts.

### 3 Instruction level

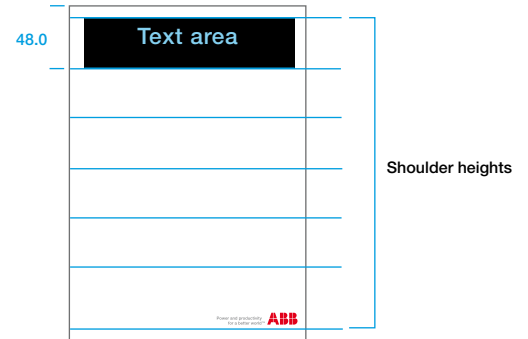

At instruction level 3 the design space follows the inside page grids as shown. The text area occupies 1 design space only and is dedicated to the title.

The text area is defined by the page margins of inside pages as shown below.

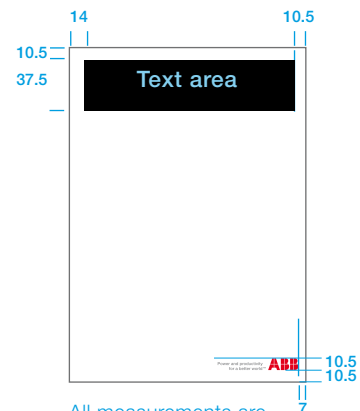

All measurements are in millimeters.

## Titles – Corporate image level

### Titles and subtitles

Titles and subtitles are featured prominently, using colors from one of the segments chosen as described on page 8.

Do not merge titles and subtitles onto one line – start them on separate lines as shown opposite. Use no more than 5 lines of text.

Use the following specification for title and subtitle text:

#### 1 Title and subtitle

**Font:** Helvetica Neue Light  
**Size:** 28 pt, line spacing 30.3 pt, tracking 25

In special cases, where there is no suitable imagery available, a typography-only cover alternative is permitted. Use no more than 10 lines of text. The color selected is taken from one color wheel segment, circles 3 and 4. Text specifications are as follows:

#### 2 Title and subtitle

**Font:** Helvetica Neue Light  
**Size:** 52 pt, line spacing 55.5 pt, tracking 25

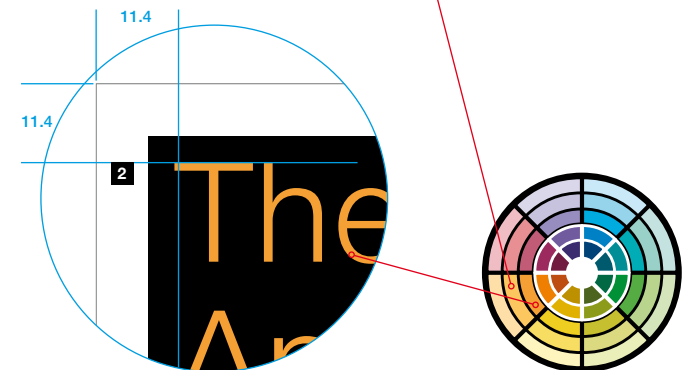
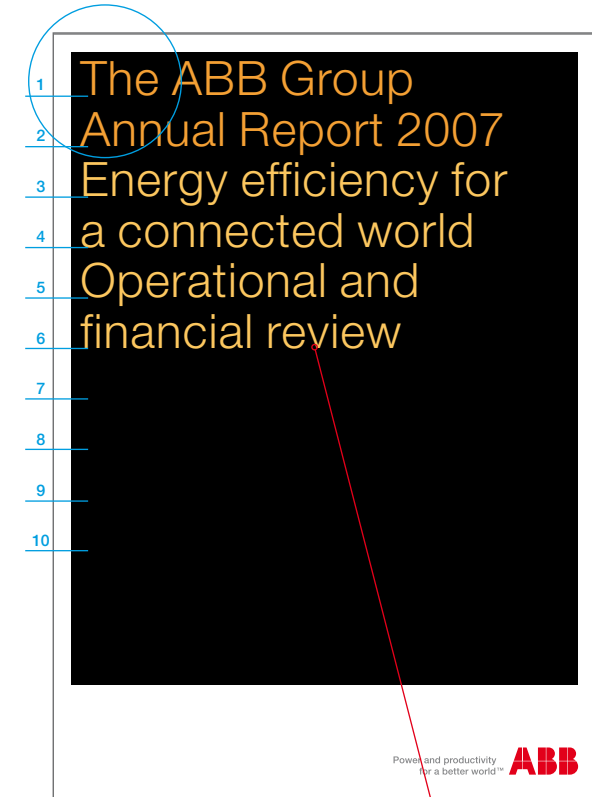
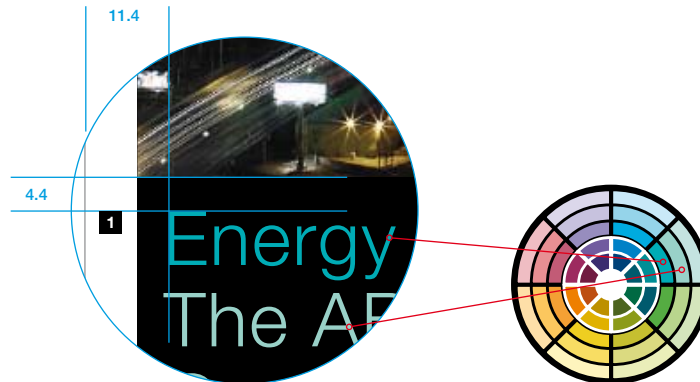
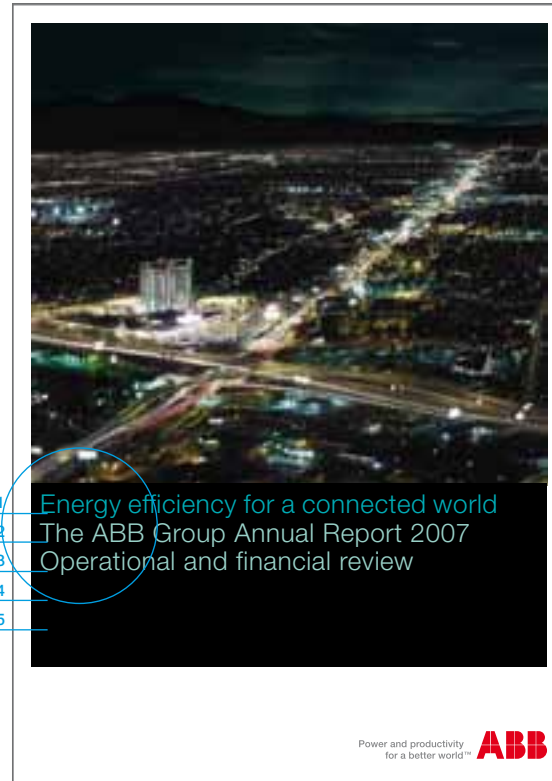

## Titles – Information and instruction levels

### Titles and subtitles

Titles and subtitles are featured prominently, using colors from one of the segments chosen as described on page 8. Do not merge titles and subtitles onto one line – start them on separate lines, as shown opposite. Use no more than 5 lines of text on information level and no more than 3 lines on instruction level.

Use the following text specifications:

#### ■ Title and subtitle

Font: Helvetica Neue Light

Size: 28 pt, line spacing 30.3 pt

#### ■ Product family or special topic title

This is optional, and may be removed as shown below.

Font: Helvetica Neue Bold

Size: 7.5 pt

Color: white

■ ■ ■ Show available text space for longer running titles.

At instruction level, use the following text specifications:

#### ■ Title and subtitle small

Font: Helvetica Neue Light

Size: 18 pt, line spacing 21 pt

#### ■ Product family or special topic title

This is optional, and may be removed as shown below opposite.

Font: Helvetica Neue Bold

Size: 7.5 pt

Color: white

### Information level

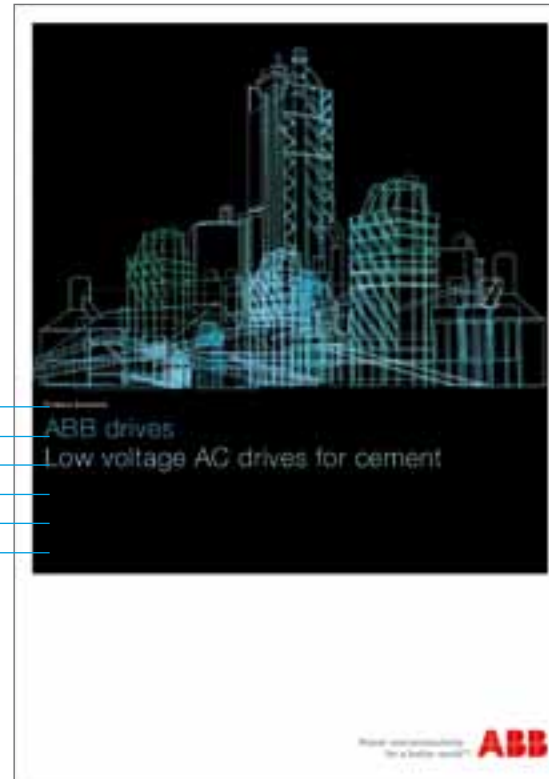

### Instruction level

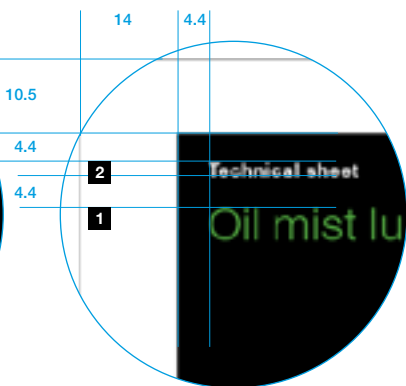
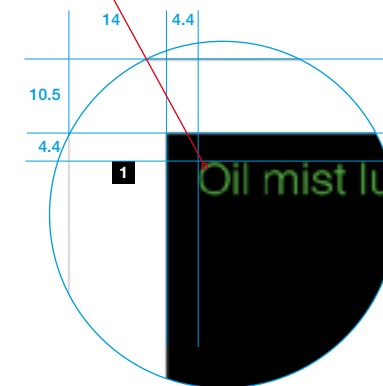
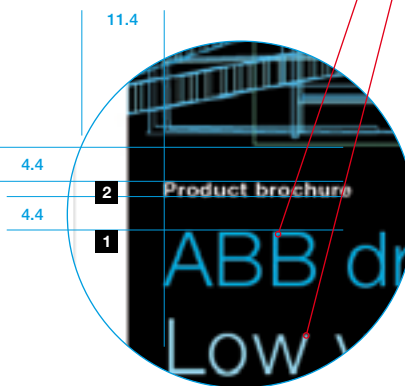
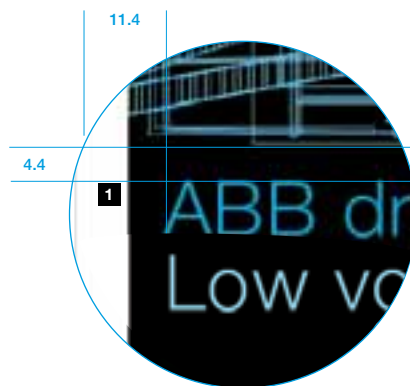

## Back covers

**1 ABB logo**  
Size and position as per front cover.

**2 Contact us**  
Font: Helvetica Neue Light  
Size: 18 pt, line spacing 21 pt

**3 Addresses and ABB web address**  
Range address information from the second to the last shoulder height (see page 23 for shoulder height explanation). If more address space is needed start a new address on the next column, as shown.

Font: Helvetica Neue Medium and Light  
Size: 9 pt, line spacing 12.4 pt  
Color: black

**4 Order number/document ID**  
Ranged vertically as shown.  
Font: Helvetica Neue Light  
Size: 6.5 pt  
Color: black

**5 Disclaimer**  
Should be featured in the third column ranged from the second shoulder height.  
Font: Helvetica Neue Medium and Light  
Size: 7 pt, line spacing 10 pt  
Color: black

**6 Certificates**  
Should be featured in the third column ranged from the second shoulder height.

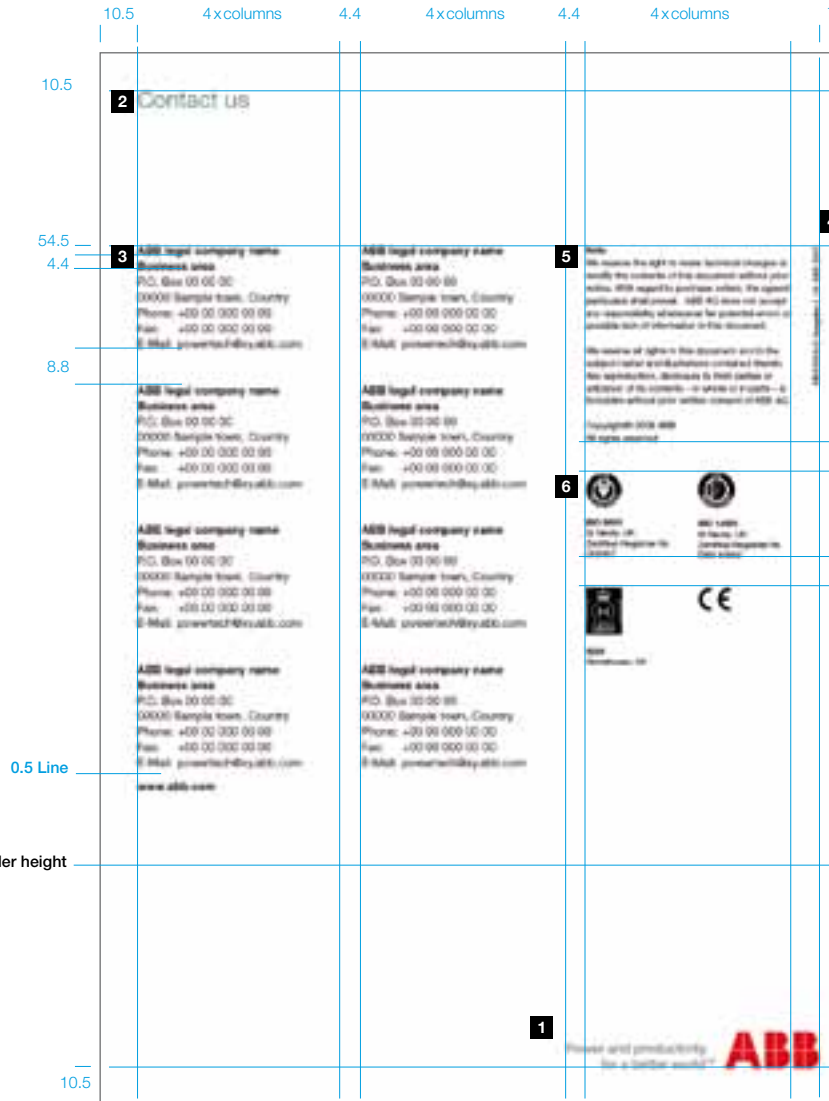

Back cover levels 1 and 2

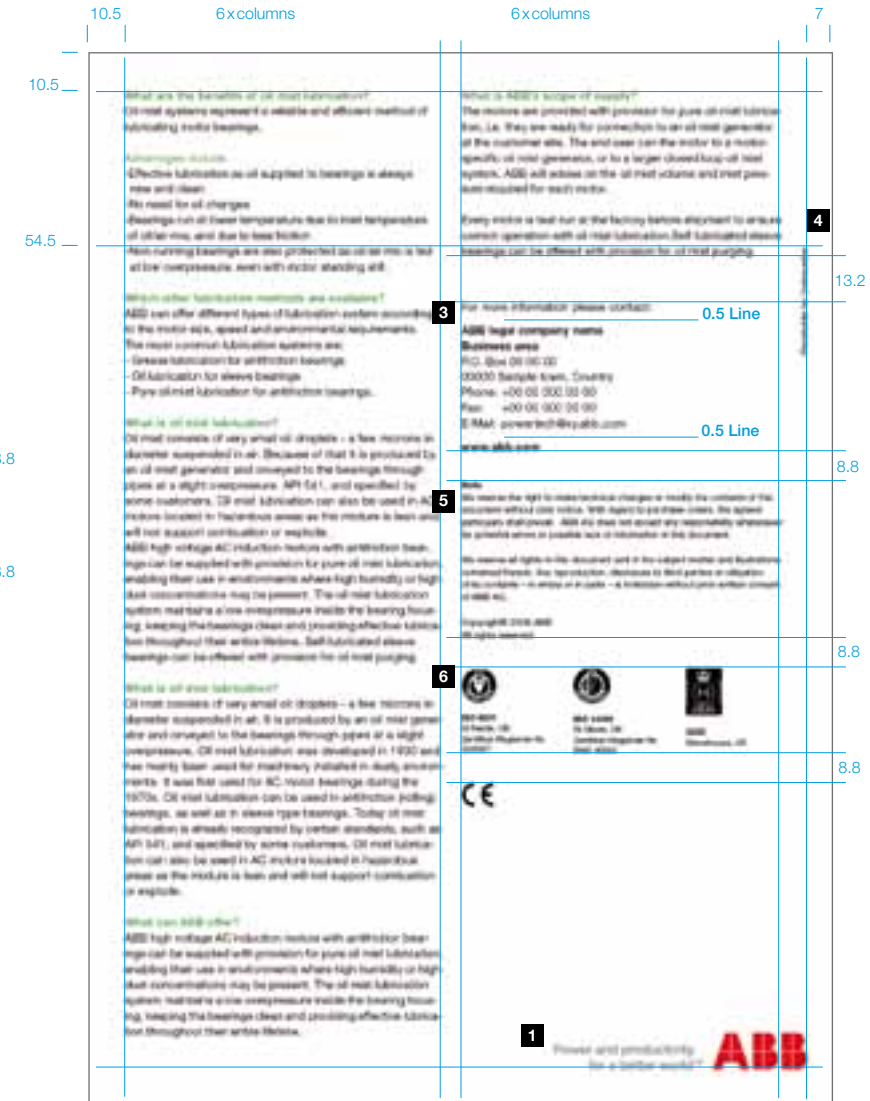

Back cover level 3

### Background



**A clean world is essential**

The demand for clean water is increasing. The world's population is growing, and the demand for clean water is increasing. The world's population is growing, and the demand for clean water is increasing. The world's population is growing, and the demand for clean water is increasing.

### The main system components



## Profile

---

Petrochemicals  
 Chemicals & Pharmaceuticals  
 Pulp & Paper

---

**Water – it concerns us all**

It is not only water utilities but every major industry that has a need for water. Water is critical to industry. Water is the most common heat transfer fluid, cleaning fluid and solvent and often forms a significant proportion of the final product. Yet water is the most untapped source of financial and energy savings within a plant. The challenge is to use water of the appropriate quality and cost, effectively throughout the whole production process. The responsible and sustainable treatment of water is one of the most important global issues.

ABB's variable speed drives for the efficient use of water and for the purification of waste water, play a larger role in order to manage this challenge.

**Challenges facing the water sector**

ABB understands the challenges facing all users of water. Such challenges include:

- Rising cost of water – to buy and to discharge
- Availability of water is falling
- Adverse affects of water quality on processes and products
- Ever stricter anti-pollution laws
- Cost of end-of-pipe effluent treatment plant rising rapidly
- Growing public concern for both health and lifestyle

It is with these challenges in mind that ABB's engineers are working to bring the most efficient solutions to its customers.

**From petrochemical plants, chemical and pharmaceutical industries, pulp and paper mills, steel mills and coking plants, food processing and beverage industries, meat rendering facilities, the textile industry and electronic component manufacturing -water plays a critical role.**

**The use of AC drives**

With the help of variable speed AC drives, ABB aims to optimise the water supply, process use and effluent treatment to give industry a competitive advantage.

ABB drives are used in every phase of water supply and waste water plants. From the moment water is taken in at the reservoir or river, through the water treatment and pumping stations, into the distribution system, back into the sewage system and then, as final effluent, returned to the environment.

**Benefits of AC drives**

**ABB drives bring many benefits including large plant efficiency improvements, energy savings and less wear and tear on moving equipment. In addition, the drives bring:**

- Better control of the water quality
- Higher automation of the processes
- Minimising energy consumption

**All this has a major impact on the financial running of the plant and can help to:**

- Reduce cost of water supply
- Recover raw material and/ or product
- Reduce effluent treatment costs
- Improve asset life
- Increase plant availability/ output

**Where can savings be made?**

- Reduction in uncontrolled use 20-30%
- Improved control 20-30%
- Water reuse 10-20%
- Water recycle 10-20%
- Design improvements 10-20%

1 Paper mill, England | 2 Machine, Germany | 3 Train station | 4 Chocolate factory | 5 Container, Germany | 6 Paper mill, England  
 7 Machine, Germany | 8 Train station | 9 Chocolate factory | 10 Container, Germany





## The design grid

The design grid is the foundation for the layout of all inside pages. It allows a clear and well-spaced placement of all images and text. Explanation of how to use this grid is provided in the following pages. Specifications for the grid are as follows:

### Baseline grid = blue lines

Runs on 4.4 mm starting at 12.8 mm.

### Columns = gray boxes

12 columns with a 4.4 mm space between each.

### Shoulder heights = red lines

The red lines are the shoulder heights, which define where pictures should start.

### Image ends = green dotted lines

Image end lines determine where images should end, so ensuring appropriate space between image and text.

All measurements are in millimeters.

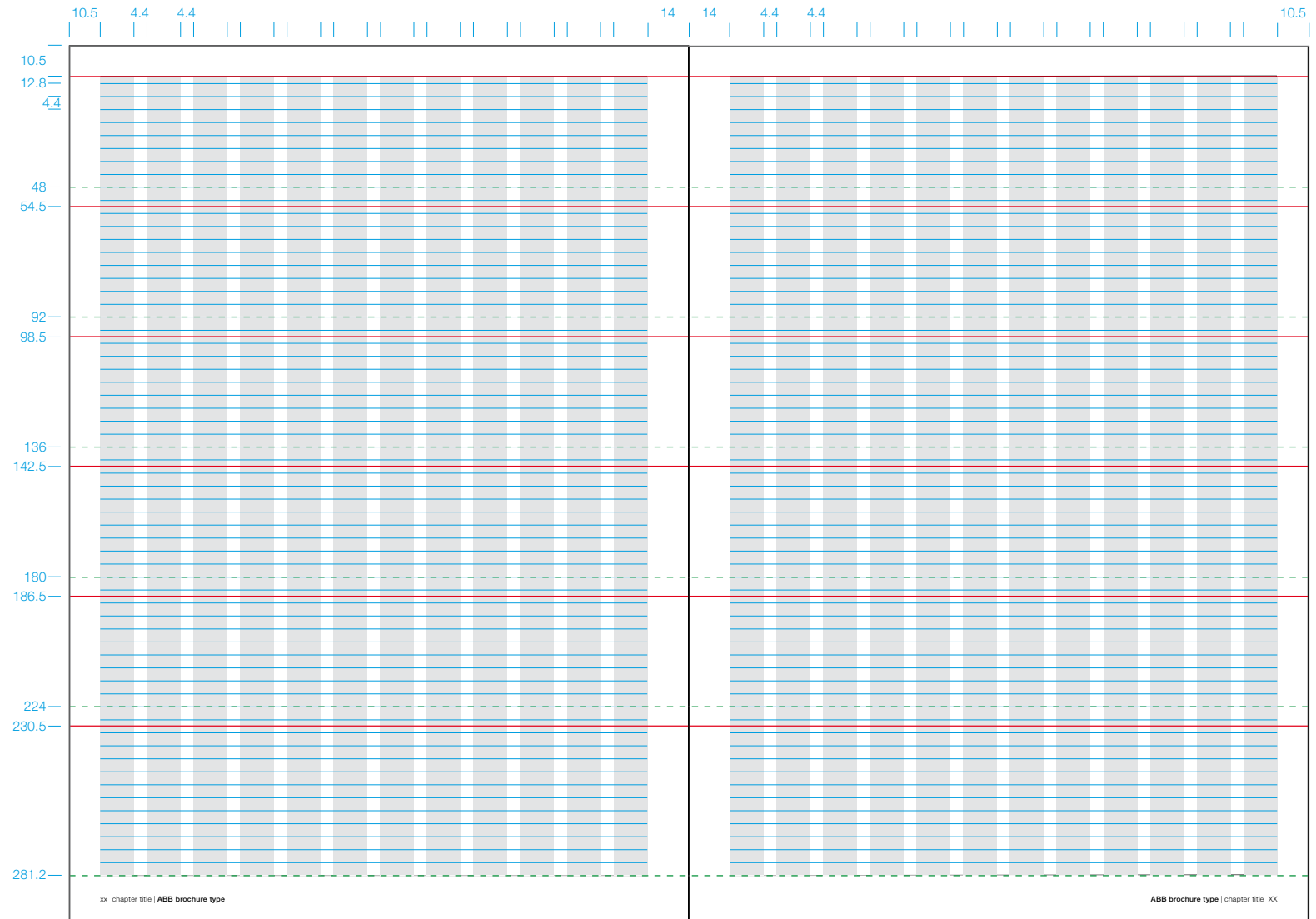

## Maximum sizes

### Double-page spreads

All images must be aligned with one of the shoulder heights. The maximum image size on a spread is the full size of the page layout with margins as defined by the white frame. The minimum height for an image on a double-page spread is 3 shoulder heights.

Images can start either from the top or the bottom of the page.

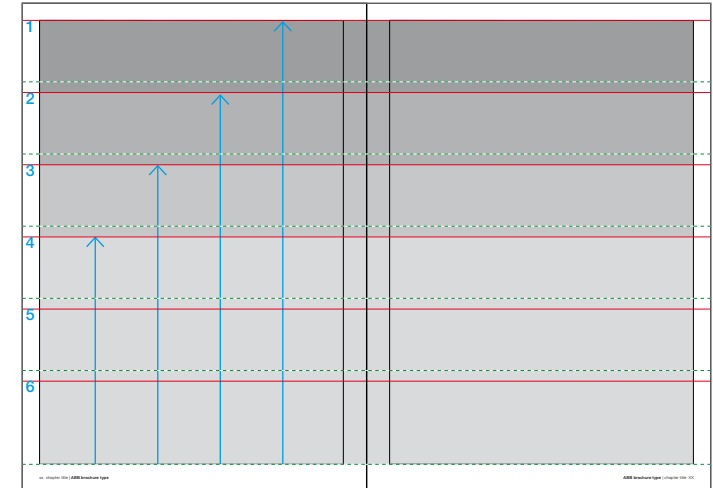
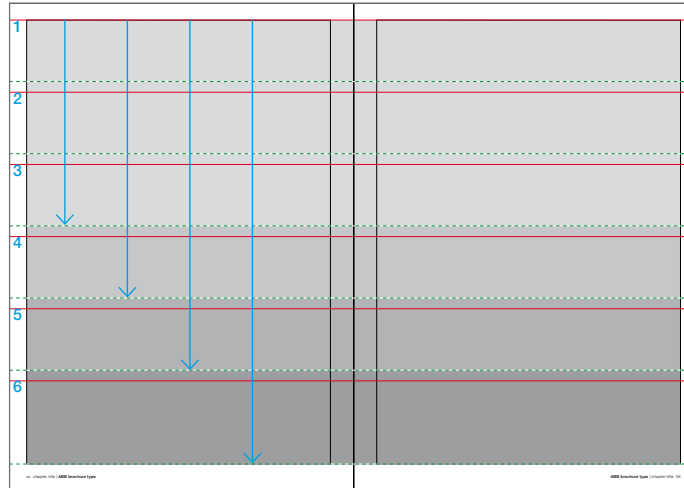

### Single pages

Images on single pages must be aligned with one of the shoulder heights. The maximum size is a full page within the margins defined by the white frame.

Images can start either from the top or the bottom of the page.

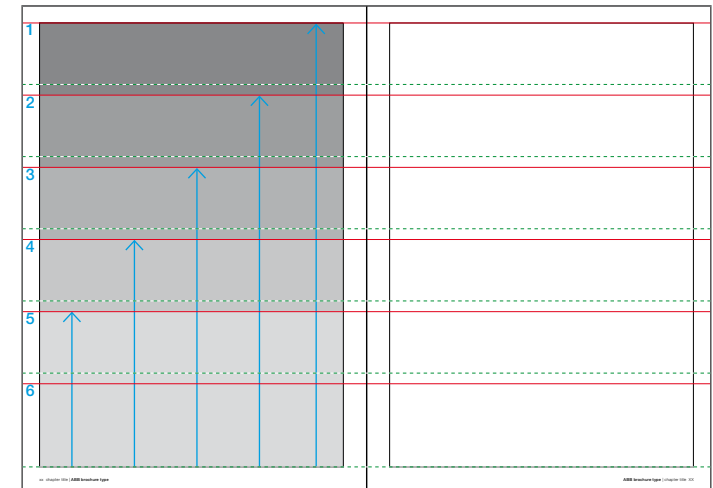
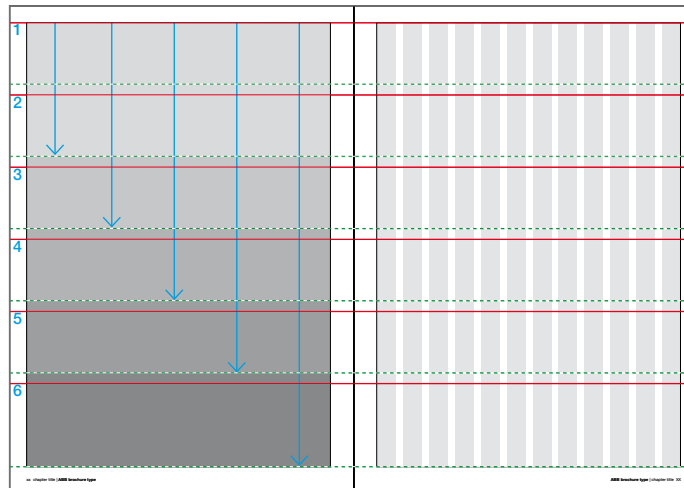

## Minimum size

For all brochure levels smaller images may be used in addition to larger sized imagery.

### 1 Single image

On 3 textcolumns the minimum size of one single image is 1 shoulder height and 4 grid column widths.  
On 2 textcolumns the minimum size of one single image is 1 shoulder height and 6 grid column widths.

The size and placement of small images is defined by an “image field” (a cluster or group of images) as described below.

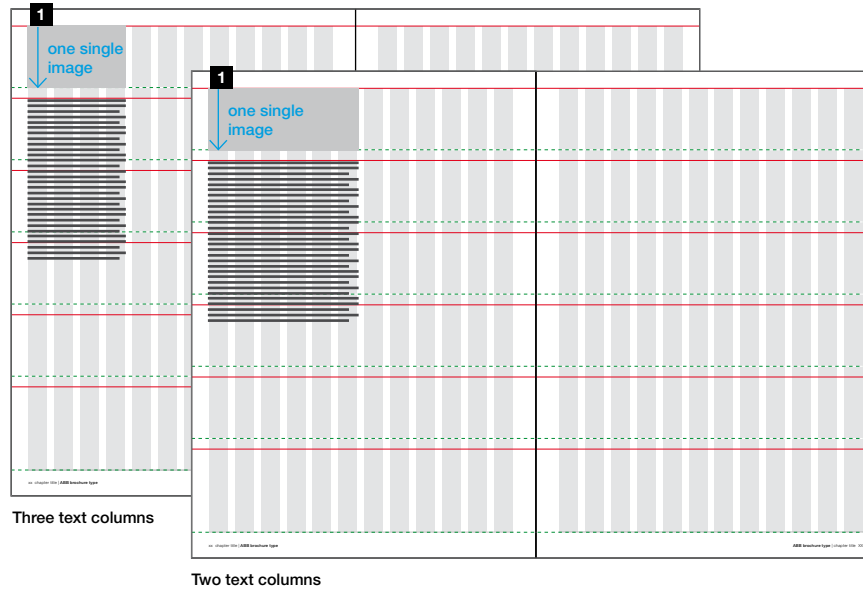

### 2 Small images

Small image fields align with the shoulder heights. Small images of equal size may be grouped together, as shown in figure 2. Images must be equally spaced: 2.2 mm horizontal spaces and 2.2 mm vertical spaces. Image groups may be placed in either half of the page.

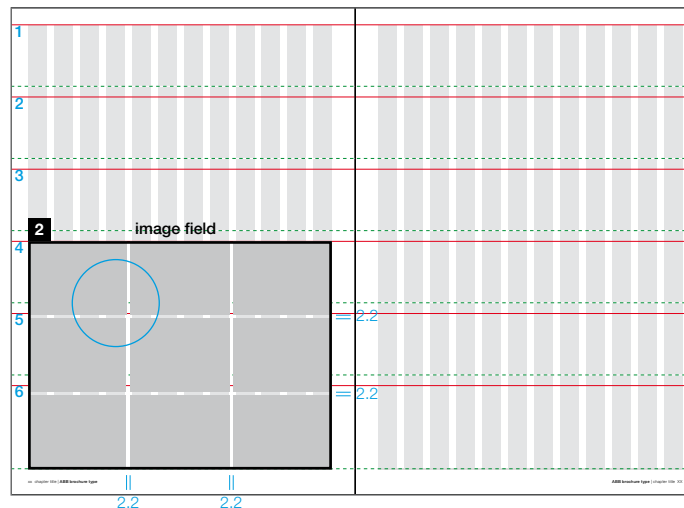

### 3 4 Single image and multi-image combinations

The smallest single image field is one shoulder height and 12 columns wide.

Different combinations of image sizes are also possible, as shown.

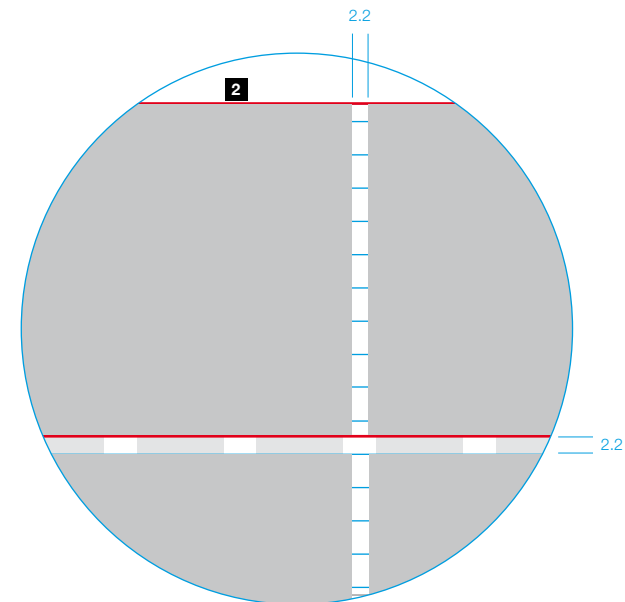
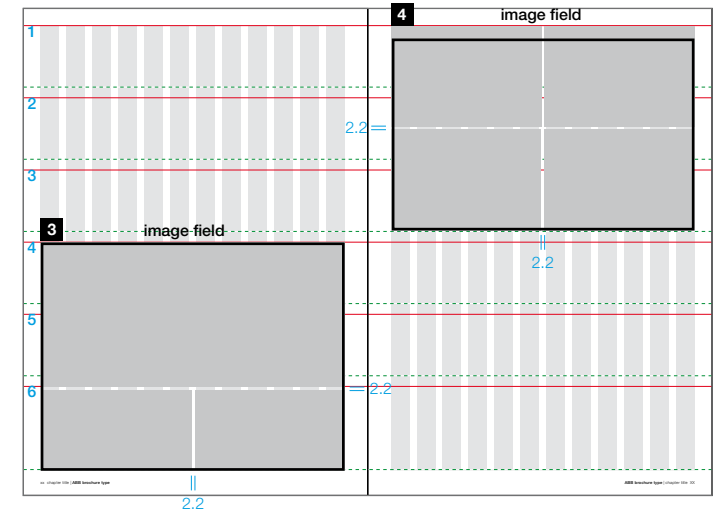

## Distance between image and text

If it is not possible to align images with shoulder heights eg, because the body text is too long, use the baseline grid (identified by the solid blue lines) to determine where images should start and finish.

### 1 Distance between image and headline

Always leave 4 lines between headlines and images. Two or more images with a 2.2 mm space between are treated as a single image field.

### 2 Distance between image and body text

Leave 1.5 lines between images and body text.

### 3 Single images

A single image must sit within the column grid.



## Examples

Text and images aligned with shoulder heights.

Large-scale images are used in conjunction with white space to create high-impact.

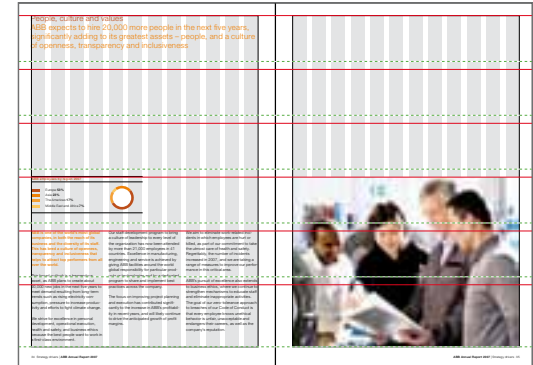
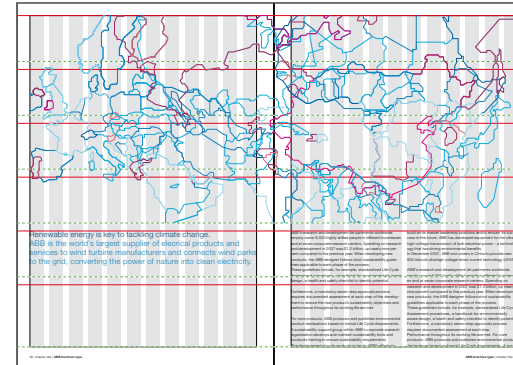
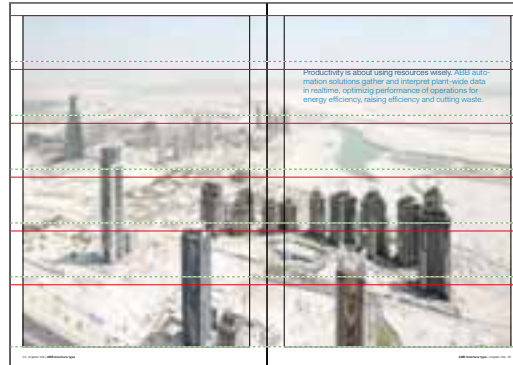

Treat small, grouped images as a single-image field.

When screenshots are used as images add a 60% blackline surround. The stroke of the line is 0.5pt.

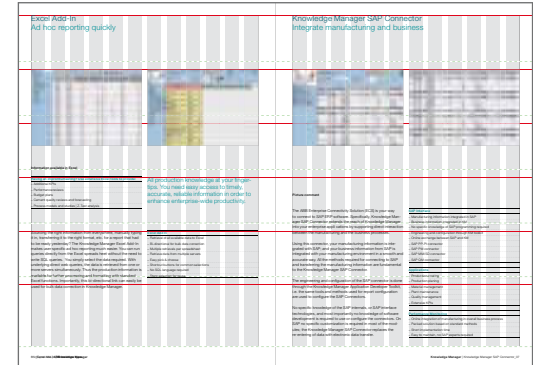

Where the content does not allow images to be aligned with shoulder heights, images must be aligned with the baseline grid.

Note: All examples shown opposite are separate pages.

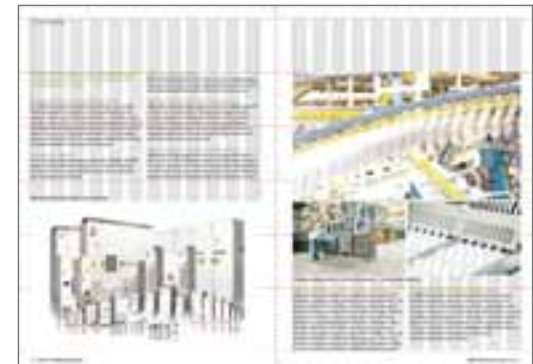

## Using the 12-column grid

The 12-column grid enables one-column, two-column and three-column text layout options, as shown overleaf.

All lines are defined by the page layout margins and the baseline grid, which runs on 4.4 mm starting at 12.8 mm (from the top).

### Red lines = shoulder heights.

The red lines are the shoulder heights, which define where text commences. At corporate image level text and images always start on shoulder heights. At information and instructional levels two and three, text aligns with the shoulder heights whenever possible.

If it is not possible to align text on shoulder heights, use the baseline grid to define where text starts and ends.

Always leave 3.5 lines between headlines and body text and 1.5 lines between images and body text.

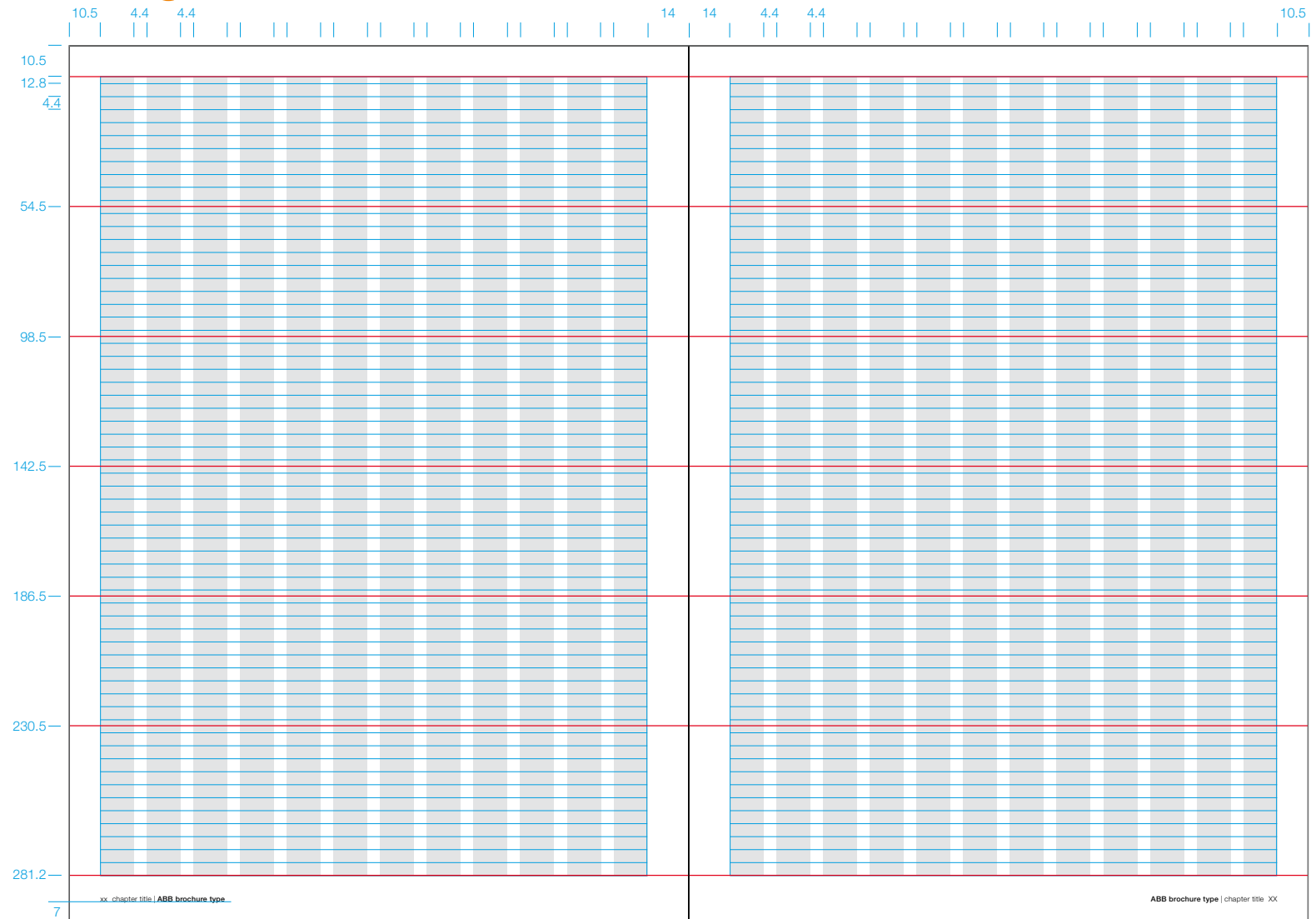

## Using the 12-column grid

All brochure levels may use the text column variations described below. Please note that for information and instruction levels a 2-text-column grid should be used wherever possible.

### One text column, with margin

(uses 8-grid columns)

For editorial text eg. CEO report.

With 1-text-column it is possible to use the small margin for quotes, text highlights and/or emphasis.

The column to the right-hand side of the body text is not used.

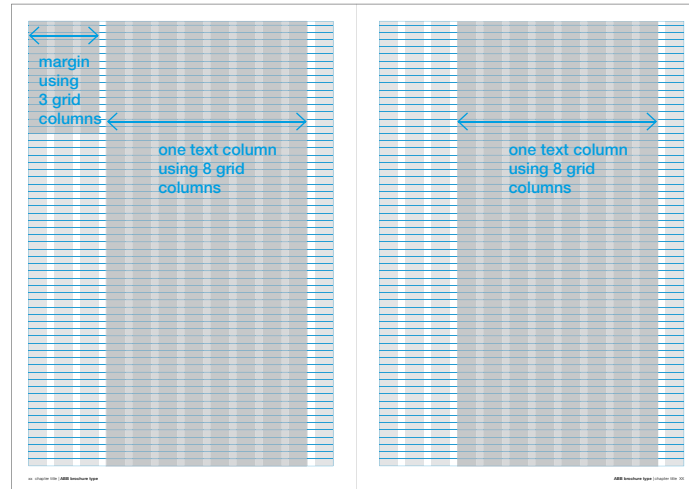

one text column with margin

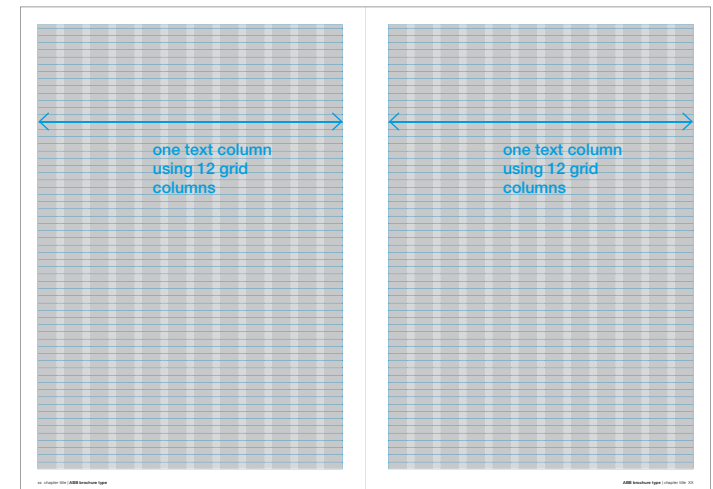

one text column full width

### One text column, full width

(uses 12-grid columns)

For extensive tables the full width of the grid is available if needed.

### Two text columns

(uses 2 x 6 grid columns)

Used for more general information, as well as tables and graphs.

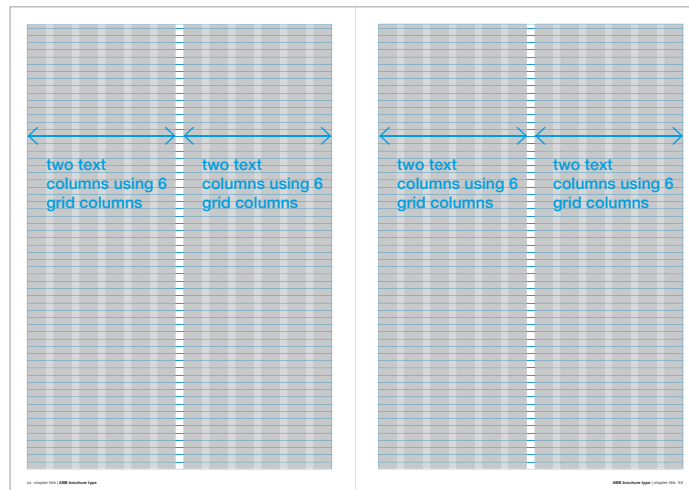

two text columns

### Three text columns

(uses 3 x 4 grid columns)

This is particularly useful for heavy text and editorial publications.

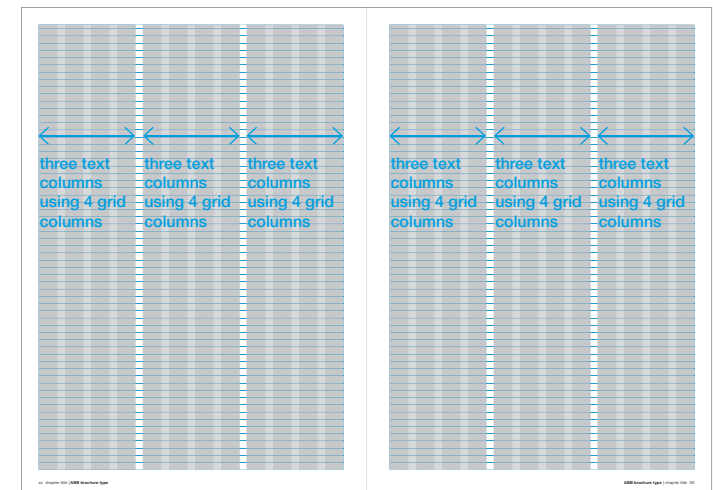

three text columns



## Examples

### Information and instruction levels 2 and 3

The examples opposite show the required predominant use of two text columns.

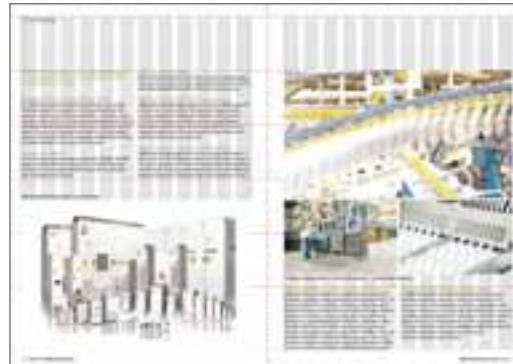

## Type sizes and line spacing for A4 and A3

ABB text is characterized by dynamic use of color and text size. Color is used in titles and headlines to create diversity (see page 8). Different type sizes are used to structure information clearly.

A clear text hierarchy has been created for different levels of information and other content. This is explained below and demonstrated opposite.

### Type only covers

See page 19 for description.  
 Use the type size given opposite.

### Cover title and page headlines

Two sizes of text are available for cover titles and inside headlines. Select the size of type according to the quantity of text and its relative importance. Choose one size only per brochure.

### Highlighted or introductory text

Two sizes of type are available for highlighting or introductory text. Again, select the size according to quantity and importance of text.

All titles, headlines, highlighted text, introductory text and body text titles must be featured in color. Text (not headlines or titles) may be featured in black if the page becomes over-saturated with color.

All body text, margin text, captions, page numbers and footnotes must be 100% black.

Type cover  
 A3 type only cover

All type specifications below refer to Helvetica Neue

Light 74 pt, LS\* 78.5 pt, T\* 25 (indd) | T\* 5 (qxd)

Type cover  
 A4 type only cover

Light 52 pt, LS\* 55.5 pt, T\* 25 (indd) | T\* 5 (qxd)

Cover title and page headlines

Light 28 pt, LS\* 30.3 pt, T\* 25 (indd) | T\* 5 (qxd)

Smaller cover title and page headlines

Light 18 pt, LS\* 21 pt, T\* 25 (indd) | T\* 5 (qxd)

Highlight text for intros, etc.

Light 28 pt, LS\* 30.3 pt, T\* 25 (indd) | T\* 5 (qxd)

Highlight text for longer intros, quotes, etc.

Light 18 pt, LS\* 21 pt, T\* 25 (indd) | T\* 5 (qxd)

Special comments

Light 14 pt, LS\* 16.5 pt, T\* 20 (indd) | T\* 4 (qxd)

Intro text before body text in color

Medium 9 pt, LS\* 12.4 pt, T\* 30 (indd) | T\* 6 (qxd)

Titles for body text

Medium 9 pt, LS\* 12.4 pt, T\* 30 (indd) | T\* 6 (qxd)

Body text

Light 9 pt, LS\* 12.4 pt, T\* 30 (indd) | T\* 6 (qxd)

Picture caption

Medium 7.5 pt, LS\* 10 pt, T\* 30 (indd) | T\* 6 (qxd)

Document name

Bold 7.5 pt, T\* 50 (indd) | T\* 9 (qxd)

Margin text

Light 7 pt, LS\* 10 pt, T\* 30 (indd) | T\* 6 (qxd)

1 Caption | 2 Caption

Medium 7 pt, LS\* 10 pt, T\* 30 (indd) | T\* 6 (qxd)

Table title	2008	2007	2006
Table content	000,000	00,000	00,000

Medium 7.5 pt, LS\* 12.4 pt, T\* 30 (indd) | T\* 6 (qxd)

Table content

Light 7.5 pt, LS\* 12.4 pt, T\* 30 (indd) | T\* 6 (qxd)

\*Footnotes are the smallest entity

Light 6.5 pt, LS\* 8.3 pt, T\* 20 (indd) | T\* 4 (qxd)

10 chapter title | ABB brochure type

Light and Medium 7 pt, T\* 30 (indd) | T\* 6 (qxd)

\*LS = line spacing, T = tracking, indd = Indesign, qxd = Quark Express

## Type sizes and line spacing for A5

A clear text hierarchy has also been created for A5 brochures.

### Type only covers

See page 19 for description.

Use the type size given opposite.

### Cover title and page headlines

Two sizes of text are available for cover titles and inside headlines. Select the size of type according to the quantity of text and its relative importance. Choose one size only per brochure. Cover titles using light 28 pt must not extend beyond one line.

### Highlighted or introductory text

Two sizes of type are available for highlighting or introductory text. Again, select the size according to quantity and importance of text.

All titles, headlines, highlighted text, introductory text and body text titles must be featured in color. Text (not headlines or titles) may be featured in black if the page becomes over-saturated with color.

All body text, margin text, captions, page numbers and footnotes must be 100% black.

All type specifications below refer to Helvetica Neue	
Type cover <b>A5 cover only</b>	Light 38 pt, LS* 40 pt, T* 25(indd) T* 5(qxd)
Cover title	Light 28 pt, LS* 30.3 pt, T* 25(indd) T* 5(qxd)
Smaller cover title and page headlines	Light 18 pt, LS* 21 pt, T* 25(indd) T* 5(qxd)
Highlight text for longer intros, quotes, etc.	Light 18 pt, LS* 21 pt, T* 25(indd) T* 5(qxd)
Special comments	Light 14 pt, LS* 16.5 pt, T*20(indd) T* 4(qxd)
Intro text before body text in color	Medium 9 pt, LS* 12.4 pt, T* 30(indd) T* 6(qxd)
Titles for body text	Medium 9 pt, LS* 12.4 pt, T* 30(indd) T* 6(qxd)
Body text	Light 9 pt, LS* 12.4 pt, T* 30(indd) T* 6(qxd)
Picture caption	Medium 7.5 pt, LS* 10 pt, T*30(indd) T* 6(qxd)
<b>Document name</b>	Bold 7.5 pt, T* 50(indd) T* 9(qxd)
Margin text	Light 7 pt, LS* 10 pt, T* 30(indd) T* 6(qxd)
1 Caption   2 Caption	Medium 7 pt, LS* 10 pt, T* 30(indd) T* 6(qxd)
Table title	Medium 7.5 pt, LS* 12.4 pt, T* 30(indd) T* 6(qxd)
Table content	Light 7.5 pt, LS* 12.4 pt, T* 30(indd) T* 6(qxd)
*Footnotes are the smallest entity	Light 6.5 pt, LS* 8.3 pt, T*20(indd) T* 4(qxd)
10 chapter title   ABB brochure type	Light and Medium 7 pt, T* 30(indd) T* 6(qxd)

\*LS = line spacing, T = tracking, indd = Indesign, qxd = Quark Express

## Headline position and sizes

Headlines normally align with the first shoulder height at the top of the page, as shown opposite and specified below:

### 1 Large headline

Use same color as main headline  
**Font:** Helvetica Neue Light  
**Size:** 28 pt, line spacing 30.3 pt, tracking 25

### 2 Small headline

Use same color as main headline  
**Font:** Helvetica Neue Light  
**Size:** 18 pt, line spacing 21 pt, tracking 25

Do not mix the size of headlines in any one brochure – be consistent.

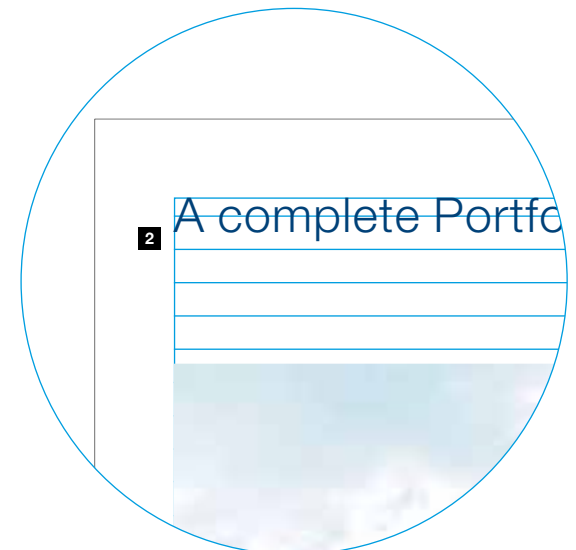
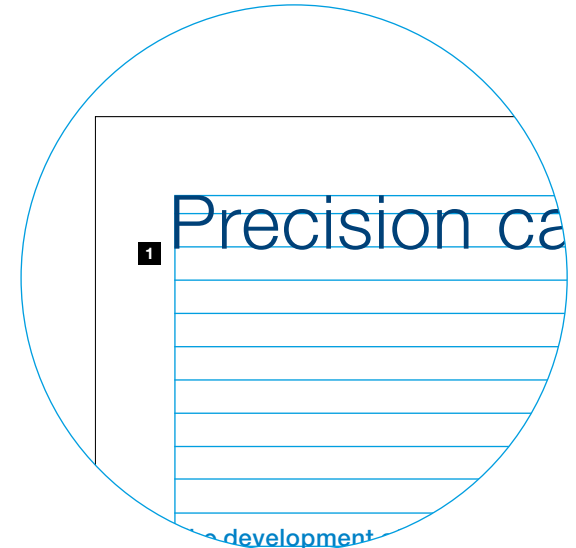
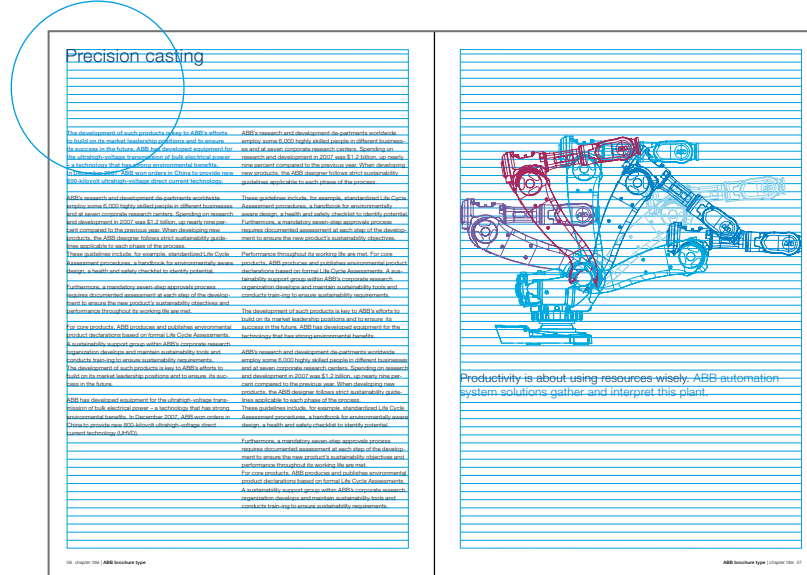

## Headline alignment with text and images

If a headline is used with text in the middle of the page, align it with the height of capital letters and/or the top edge of images.

### 1 Headline alignment with text

Align the headline with the body text, capital height of letters.

### 2 Using a headline or caption on images

Text should not interfere with the image content, and must be clearly legible. Use shoulder heights to align text.

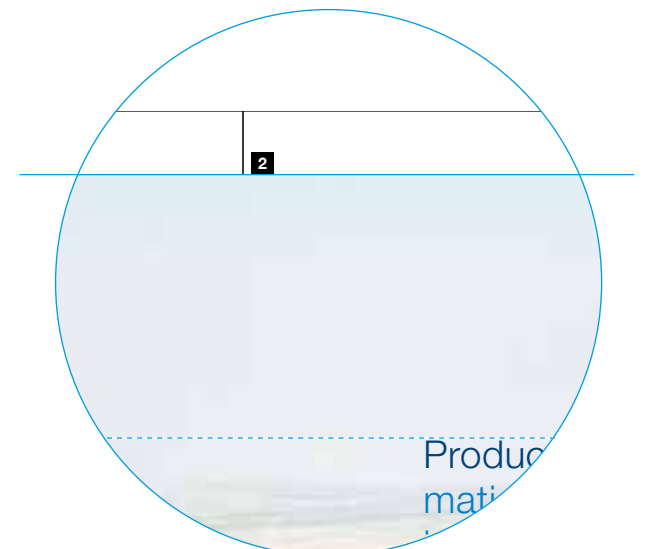
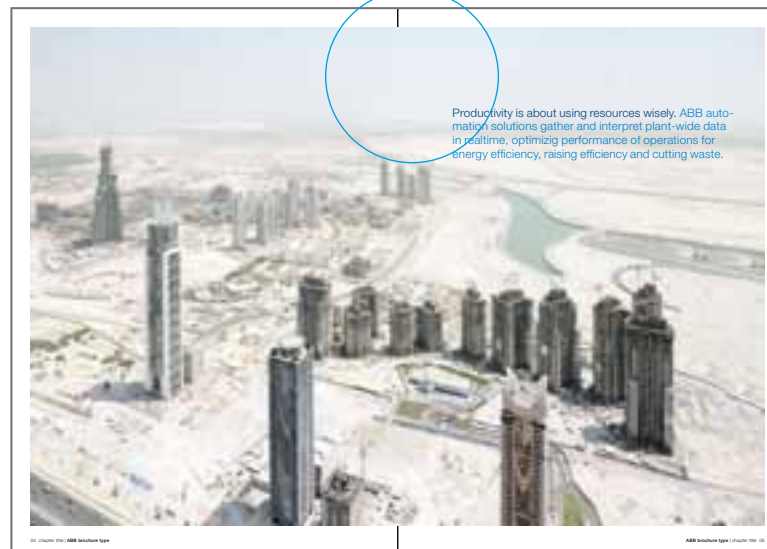
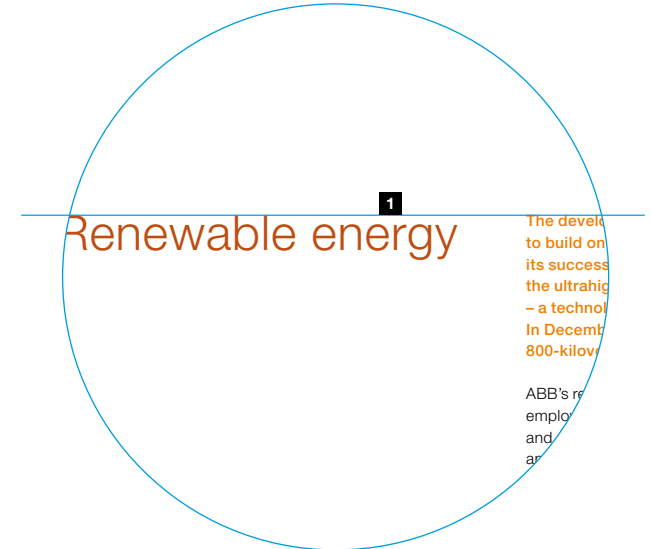
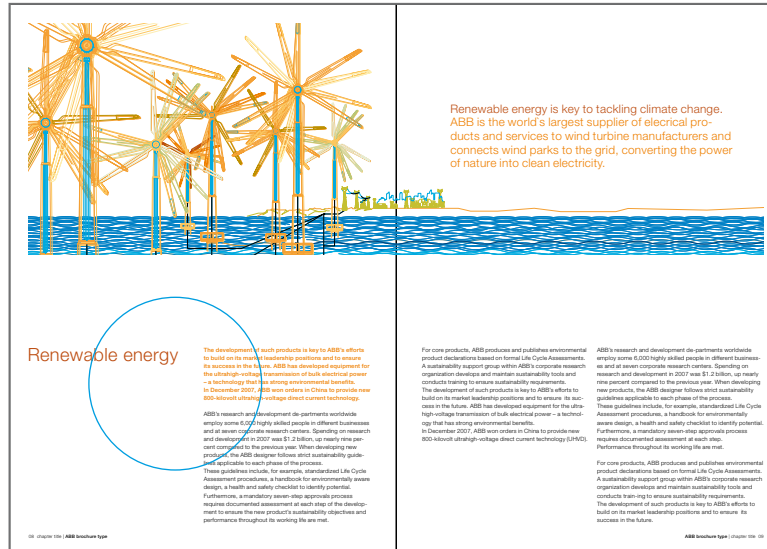

## Aligning text and images

Align all body text on the baseline grid.

### 1 Alignment

Align all images with the height of capital letters in body text. Align all body text on the baseline grid.

### 2 Colored text

Colored text may be used within the white background area of a “second level image”, provided that it does not crowd the image content. The colored text can be used to add emphasis. The color of the text must match the color used for the headline.

Colored text used on images must always use 10 columns, leaving one empty on either side.

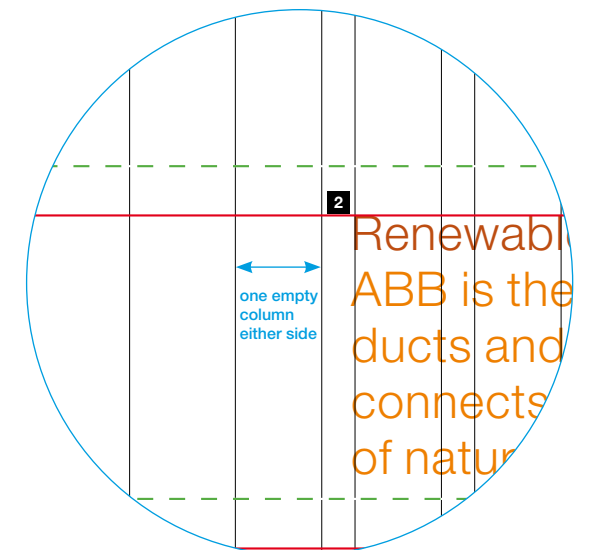
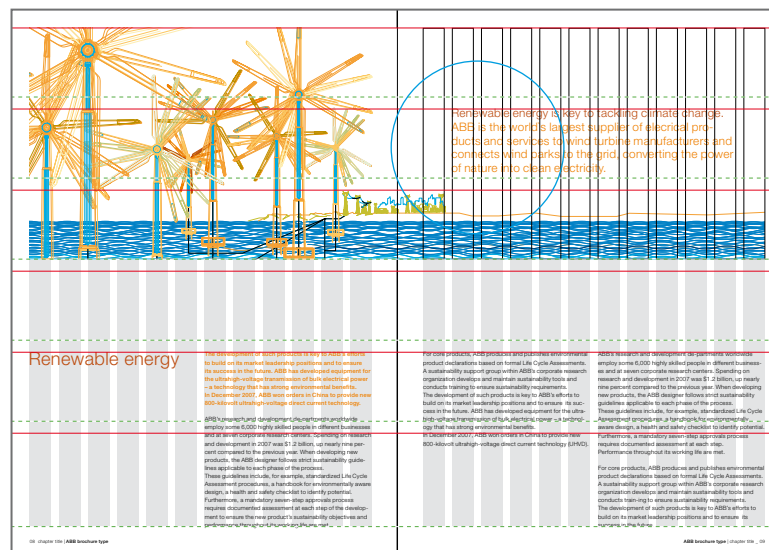
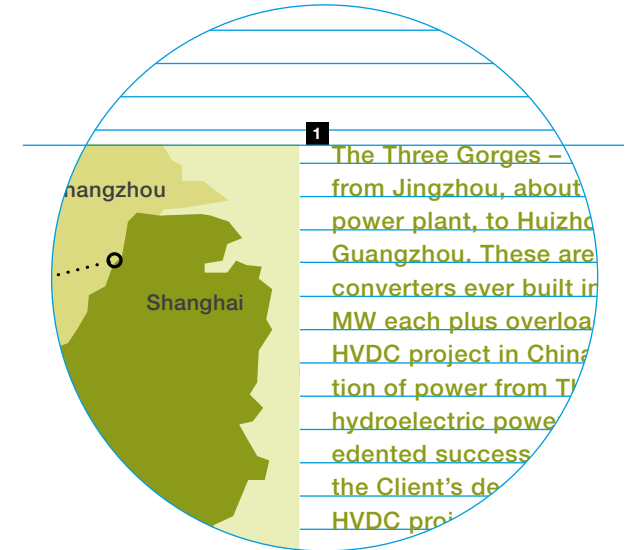

## Text hierarchies

Align highlighted introductory text with the top of shoulder heights. This text runs across the full width of the grid.

### Large highlighted text

Use the colors from circles 1 and 2 of the predominant color segment chosen for imagery on the cover. Colors may change mid-text as shown. Do not change colors within a sentence.

**Font:** Helvetica Neue Light

**Size:** 28 pt, line spacing 30.3 pt, tracking 25

### Small highlight text

Use the colors from circles 1 and 2 of the predominant color segment chosen for imagery on the cover. Colors may change mid-text as shown.

**Font:** Helvetica Neue Light

**Size:** 18 pt, line spacing 21 pt, tracking 25

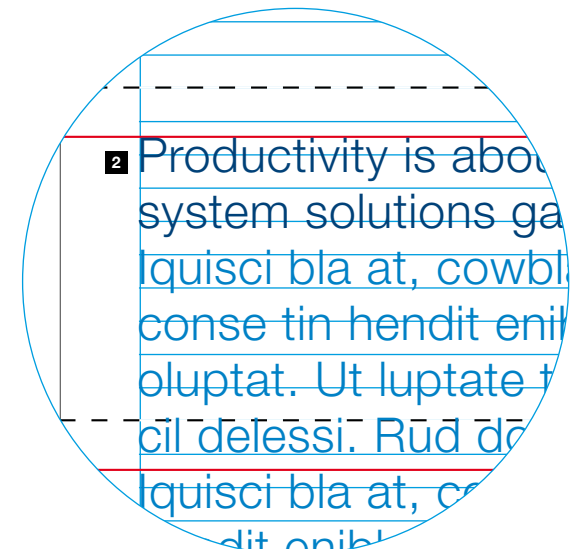
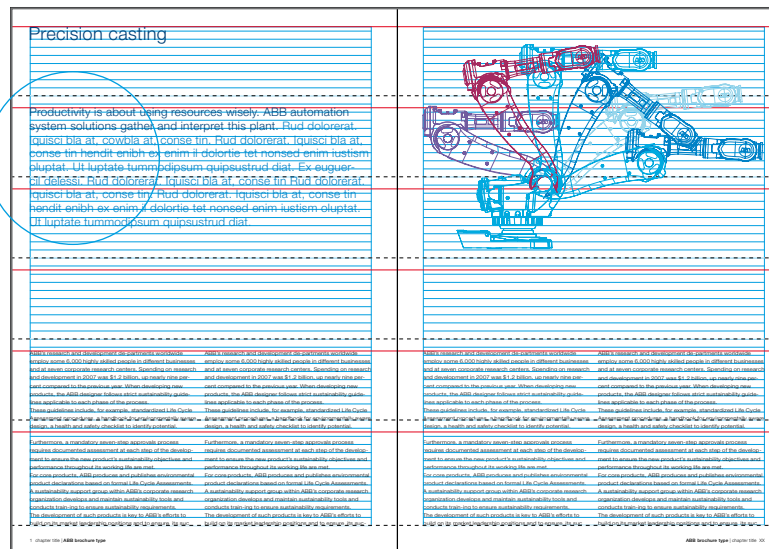
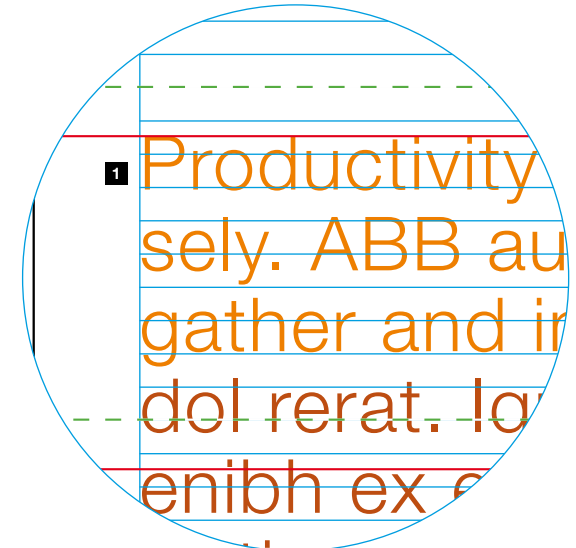
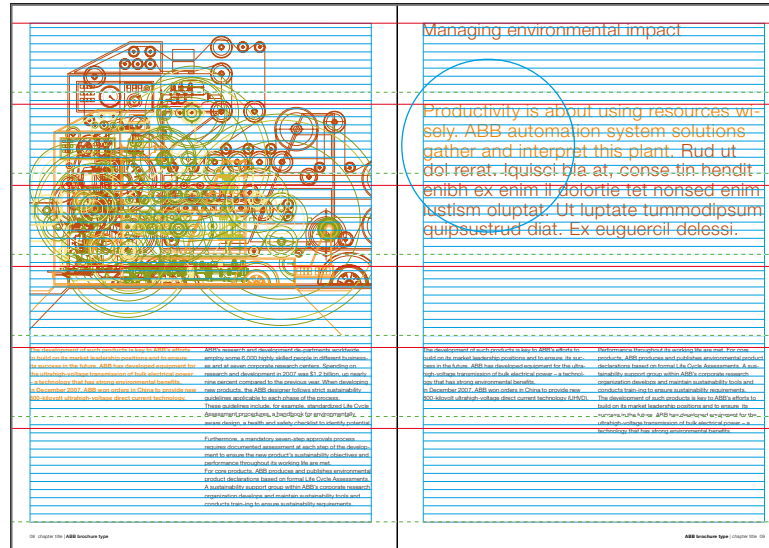

## Text hierarchies

Align all body text, captions and footnotes with the baseline grid.

### 1 Special comment

Use the colors from circle 2 of the predominant color segment chosen for imagery on the cover. Lock the first line to the baseline grid.

Font: Helvetica Neue Light

Size: 14 pt, line spacing 16 pt, tracking 30

### 2 Lead text

Use the colors from circle 2 of the predominant color segment chosen for imagery on the cover.

Font: Helvetica Neue Light

Size: 9 pt, line spacing 12.4 pt, tracking 30

### 3 Title body text

Use the colors from circle 2 of the predominant color segment chosen for imagery on the cover.

Font: Helvetica Neue Medium

Size: 9 pt, line spacing 12.4 pt, tracking 30

### 4 Body text

Font: Helvetica Neue Light

Size: 9 pt, line spacing 12.4 pt, tracking 30

Color: black

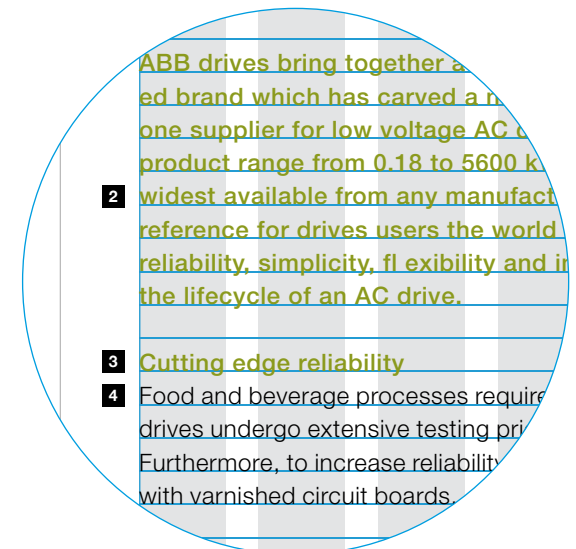
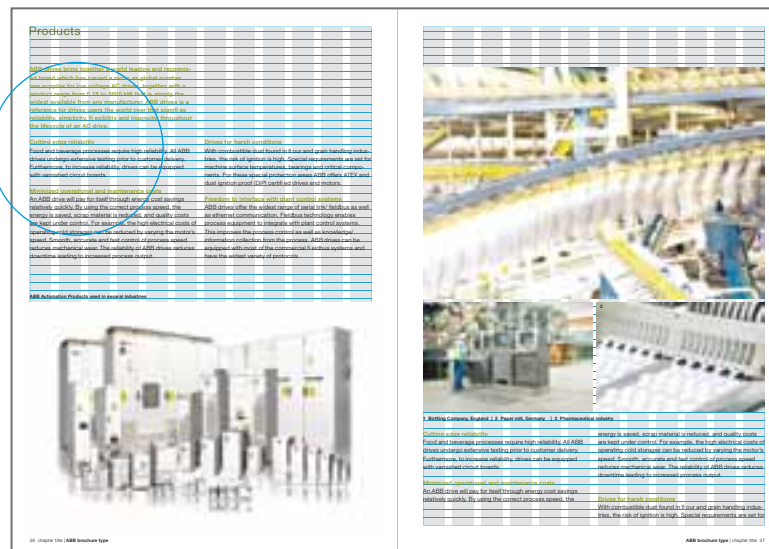
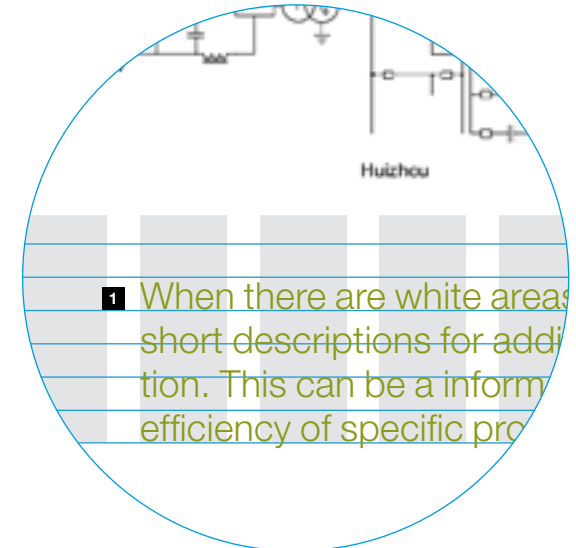

## Text hierarchies

Margins may be used to feature quotes and/or emphasise selected content.

### Margin text, small

Use black text.

The first line sits on the baseline grid.

Font: Helvetica Neue Light

Size: 7 pt, line spacing 10 pt,

tracking 30

Color: black

### Margin text, big

Use the predominant colors from the cover image. The first line sits on the baseline grid.

Colors may change mid-text.

Font: Helvetica Neue Light

Size: 14 pt, line spacing 16,5 pt,

tracking 20

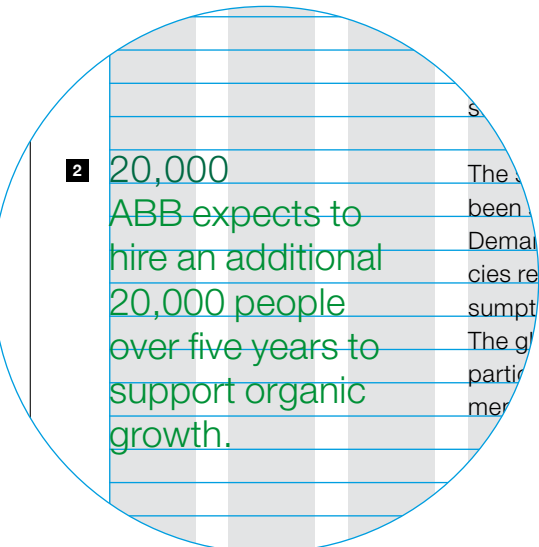
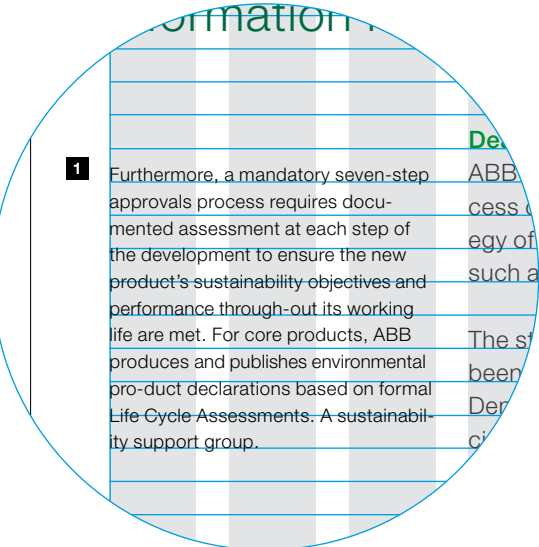

## Text hierarchies

Align all body text, captions and foot-  
notes align with the baseline grid.

### 1 Page numbers and text

All pages must be numbered. In longer  
brochures it is also advisable to repeat  
the chapter heading and brochure title  
as shown opposite.

**Font:** Helvetica Neue Light  
and Helvetica Neue Medium

**Size:** 7 pt, tracking 30

**Color:** black

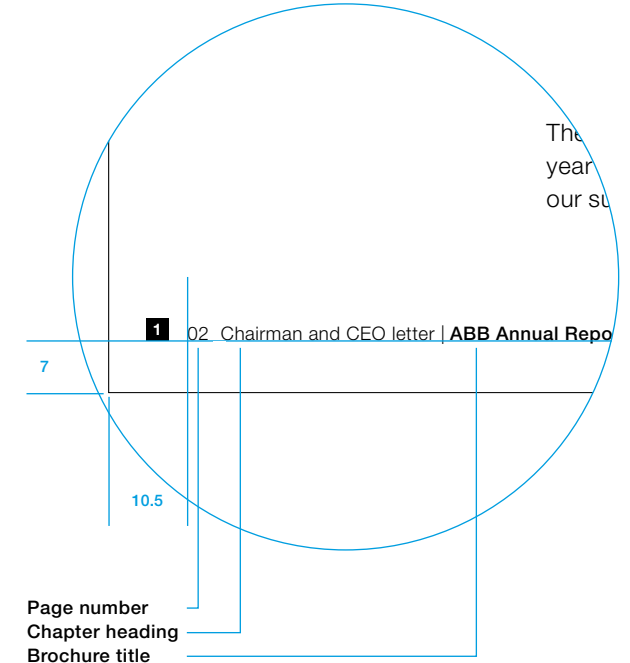
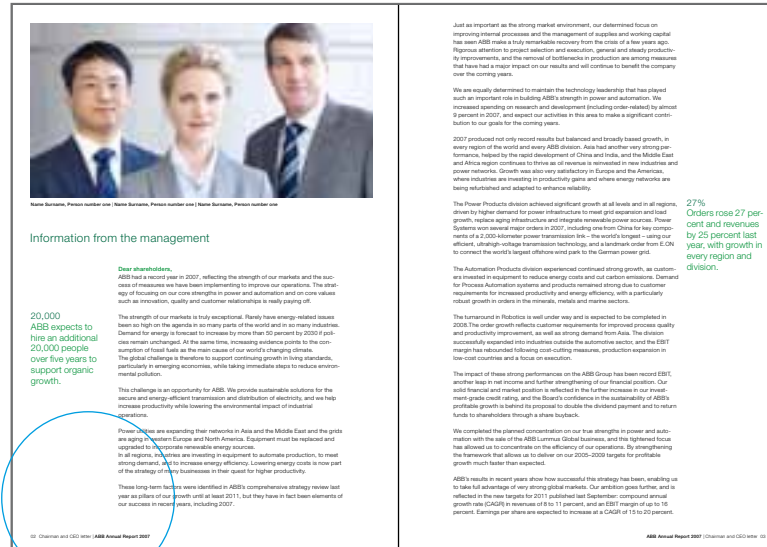

## Text hierarchies

Align all body text, captions and foot-  
notes with the baseline grid.

### 1 Picture caption below image

If a picture caption has more than  
one line, the first line sits on the  
base-line grid.

**Font:** Helvetica Neue Medium

**Size:** 7.5 pt, line spacing 10 pt,  
tracking 30

**Color:** black

### 2 Picture caption above image

If a picture caption has more than  
one line, the last line sits on the  
baseline grid.

**Font:** Helvetica Neue Medium

**Size:** 7.5 pt, line spacing 10 pt,  
tracking 30

**Color:** black

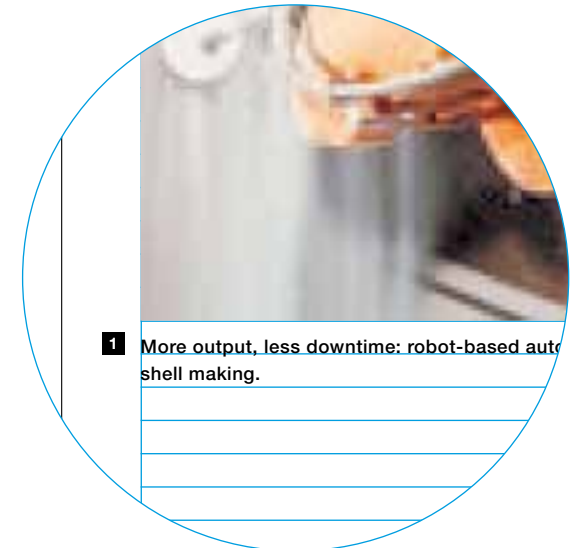
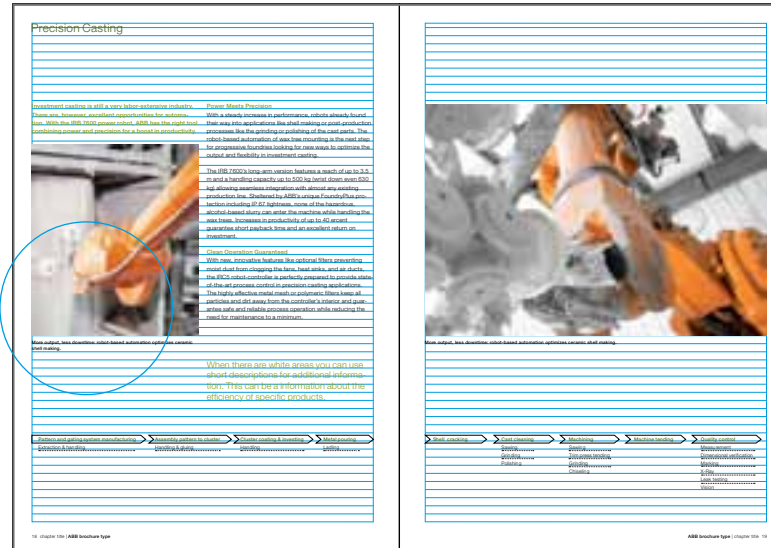

1 More output, less downtime: robot-based auto shell making.



2 Paper mill, England | 2 Machine, Germany  
7 Machine, Germany | 8 Train station | 9

## Tables

The lines used in tables run in between the lines of the baseline grid so that the text sits on the baseline grid.

### 1 Table title

Font: Helvetica Neue Medium

Size: 7.5 pt, line spacing 12.4 pt, tracking 30

### Table title lines

Rule above and below: 0.25 pt

Offset: 0.7 mm

Color: colored-using circle 2 from the color wheel, following the color segment chosen for the chapter.

### 2 Table text

Font: Helvetica Neue Light

Size: 7.5 pt, line spacing 12.4 pt, tracking 30

### Table text lines

Rules below: 0.5 pt, dotted

Offset: 0.7 mm

Color: black

### 3 Footnotes

Font: Helvetica Neue Light

Size: 6.5 pt, line spacing 8.3 pt, tracking 20

Color: black

### 4 Vertical divider lines

0.5 pt, dotted

Color: black

4			
used in industrial batteries are recycled materials.			
1	<b>EN8 Water consumption (kilotons)</b>	2006	2005 2004
2	Purchased from water companies	3,431*	3,432 3,200
	Groundwater extracted by ABB**	2,700	2,500 2,500
	Surface water extracted by ABB**	2,500	1,700 1,000
3	*The figure is based on reported data from 83 percent of employees and an assumed water consumption of ten tons/year/employee for the remaining 17 percent of employees. **Estimated (rounded) figures		
	<b>EN19 Emissions of ozone-depleting substances (tons)</b>	2006	2005 2004
	Volatile Organic Compounds (VOC)	992	981 861
	Chlorinated Volatile Organic Compounds (VOC-Cl)	29*	13.5 22

4			
paper, oil and plastic. ABB's aim is to reduce the amount of waste sent to landfill and to increase its use of materials which are recycled or made available for reuse.			
	<b>EN23 Numbers of significant spills</b>	2006	2005 2004
	Oil spills	3	8 7
	Chemical spills	0	7 2
	Emissions to air	1	3 1
	Others	0	1 2

4			
1	<b>Year ended December 31 (in millions)</b>	2007	2006 2005
	<b>Operating activities:</b>		
	Net income	\$ 3,757	\$ 1,390 \$ 735
	<b>Adjustments to reconcile net income to net cash provided by operating activities:</b>		
	Depreciation and amortization	602	570 597
	Provisions, net	(362)	243 466
	Pension and postretirement benefits	(61)	(4) (62)
	Deferred taxes	(351)	113 38
	Net gain from sale of property, plant and equipment	(46)	(76) (44)
	Income from equity accounted companies	(55)	(95) (109)
	Minority interest	246	179 131
	Loss (gain) on sale of discontinued operations	(541)	- 16
	Other	132	190 159
	<b>Changes in assets and liabilities:</b>		

## Graphs

Align the axes of graphs and calibration lines with the baseline grid.

### 1 Graph title

**Font:** Helvetica Neue Medium  
**Size:** 7.5 pt, line spacing 12.4 pt, tracking 30  
**Graph title lines**  
 Rule above and below: 0.3 pt, Offset 0.7 mm  
**Color:** black

### 2 Graph text

**Font:** Helvetica Neue Light  
**Size:** 7.5 pt, line spacing 12.4 pt, tracking 30  
**Color:** black

### 3 Graph axes and calibration lines

Rules around graph: 0.5 pt, color black  
 rules inside graph: 0.35 pt, dotted, color black.

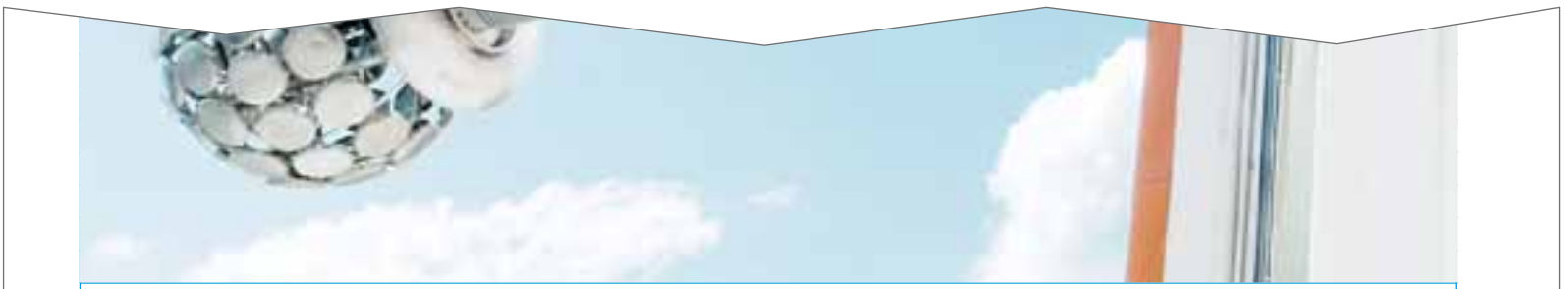

**UHVDC test circuit, Ludvika, Sweden**

**Global experience – Local solutions** **1** Transmission of 6000 MW over 2000 km. Total evaluated costs in MSUD

Whatever your expectations, your installed power and the size of your network, ABB has a full portfolio of services resulting in solutions for all events. Each and every job on- or off-site is the result of a fair and accurate assessment utilizing highly developed skills and technical tools. Our solutions take all factors such as technical, financial, environmental and safety aspects into account. The result is a reliable and long-lasting solution.

ABB has over 50 transformer facilities and more than 15 service centres worldwide backed up by a permanent research and development program aimed at ensuring benefits for our customers. Our service and repair teams are available 24 hours a day. It does not matter where you are on the five continents – your ABB partner is ready with all its knowledge and worldwide expertise to ensure that you get the best you deserve in a record time. Dedication to service is a rare phrase nowadays – at ABB it is still alive.

**Condition / Risk Assessment**  
 Solid knowledge of the equipment status based on history, design review and advanced diagnosis, anticipated fault detection, corrective action planning enables greater reliability and

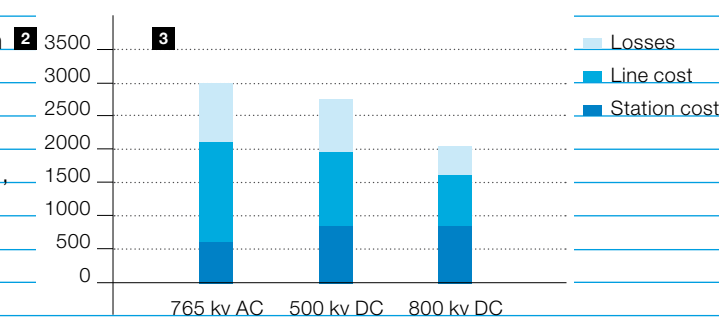

System	Station cost	Line cost	Losses	Total
765 kv AC	~500	~1500	~1000	~3000
500 kv DC	~700	~1200	~800	~2700
800 kv DC	~600	~900	~500	~2000

**Financial**  
 There are three main aspects to the financial evaluation:  
 – Transmission system losses  
 – The investment cost for the line  
 – The investment cost for the converter station and associated AC switchgear

The diagram below illustrates the cost differences between 765 kv AC, 500 kv DC and 800 kv DC. The example is for a 2 000 km long line to transmit 6 000 MW.

## Quality brochure reproduction

Opposite is some general guidance on how to achieve quality production of brochures. It is vital to always check requirements with your printer who will then advise on the optimal paper weight and binding technique depending on the desired quality and length of your brochure.

### Important information for printing CMYK

1. The density value for black, measured on the wet printed sheet, should be DV 1.75 to DV 1.80. Tolerance +/- 0.03
2. The order of colors for CMYK print is black, cyan, magenta and yellow.

**Always use a matt varnish to seal all images.**

**Use FSC-certified paper for all publications, selecting either matt standard coated, satin-finish or ultra-white (blue-tinge rather than yellow-tinge) paper.**

**Perfect bound brochures (see 3 opposite): used particularly for brochures of over 50 pages.**

#### Minimum 4mm spine width

<b>A4/U.S.</b>	Cover: 250-300 gm <sup>2</sup>
	Inside pages: 135-150 gm <sup>2</sup>
<b>A5</b>	Cover: 200-250 gm <sup>2</sup>
	Inside pages: 115-135 gm <sup>2</sup>

#### Wire-stitched brochures (see 1 2 opposite)

<b>A4/U.S.</b>	Cover: 200-250 gm <sup>2</sup>
	Inside pages: 90-150gm <sup>2</sup>
	Self-cover: 115-150gm <sup>2</sup>
<b>A5</b>	Cover: 170-200 gm <sup>2</sup>
	Inside pages: 115-150gm <sup>2</sup>
	Up to 12 pages: 150-170gm <sup>2</sup>
<b>A6</b>	Cover: 150-170 gm <sup>2</sup>
	Inside pages: 115-135 gm <sup>2</sup>
<b>Folder</b>	300-350gm <sup>2</sup>
<b>Fact Sheets</b>	150-170gm <sup>2</sup>

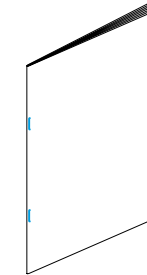

### 1 Saddle stitch brochure, two wires

This is the most typical binding style likely to be selected for information and instruction levels.

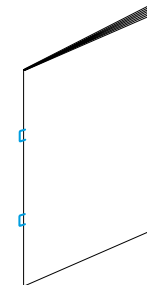

### 2 Eyelit stitching or punch hole stitch

Enables brochures to be filed in a folder.

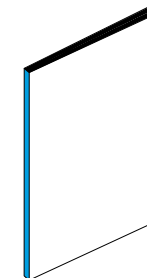

### 3 Perfect Bound

Use for high quality brochures, in cases where a thicker paper weight is selected, or when the total number of pages is around sixty or more.

## Revision history

### **Nov 18th 2011**

Adjustments of specifications in lower circle and text adjustment on page 19 and 20.

Adding blue exclamation mark on page 18.