



ABB Sp. z o.o.
ul. Starowińska 13a
31-038 Krakow

Project description : Laboratorium AGH

Project number :

Performer : ABB sp. z o. o.

Project name : Laboratorium AGH

			Date	2015-03-02	Laboratorium AGH		ABB sp. z o. o. Starowislna 13a 31-038 Krakow	Main Page: SZS	Electrical diagrams	= AGH	Page no. 3	
			Edit	R.Zbien						+ SZS		Pages 37
			Check	M.Borkowski								
Change	Date	Name	Appr	W.Kolomyjski					Doc. no.			

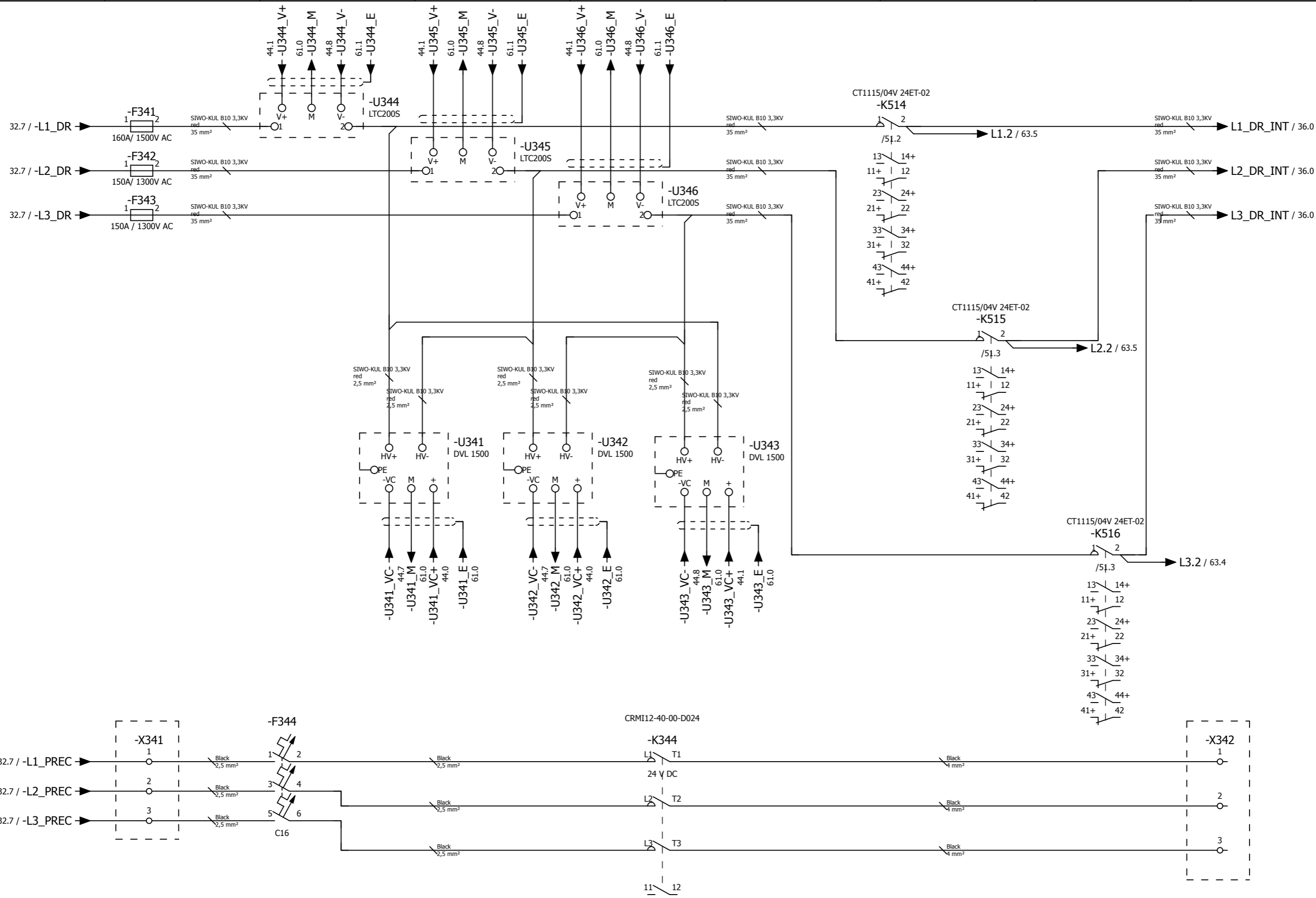

INTERNAL DIODE RECTIFIER

CONVERTER PRECHARGE

ABB SP. Z O. O. RESERVES ALL RIGHTS IN THIS DOCUMENT AND IN THE INFORMATION CONTAINED THEREIN. REPRODUCTION, USE OR DISCLOSURE TO THIRD PARTIES WITHOUT EXPRESS AUTHORITY IS STRICTLY FORBIDDEN.

				Laboratorium AGH				ABB sp. z o. o. Starowislna 13a 31-038 Krakow		Main circuit of SZS		Electrical diagrams		= AGH	
		Doc. no.												+ SZS	
Change	Date	Name	Appr	W.Kolomyjski								Page no. 34		Pages 37	

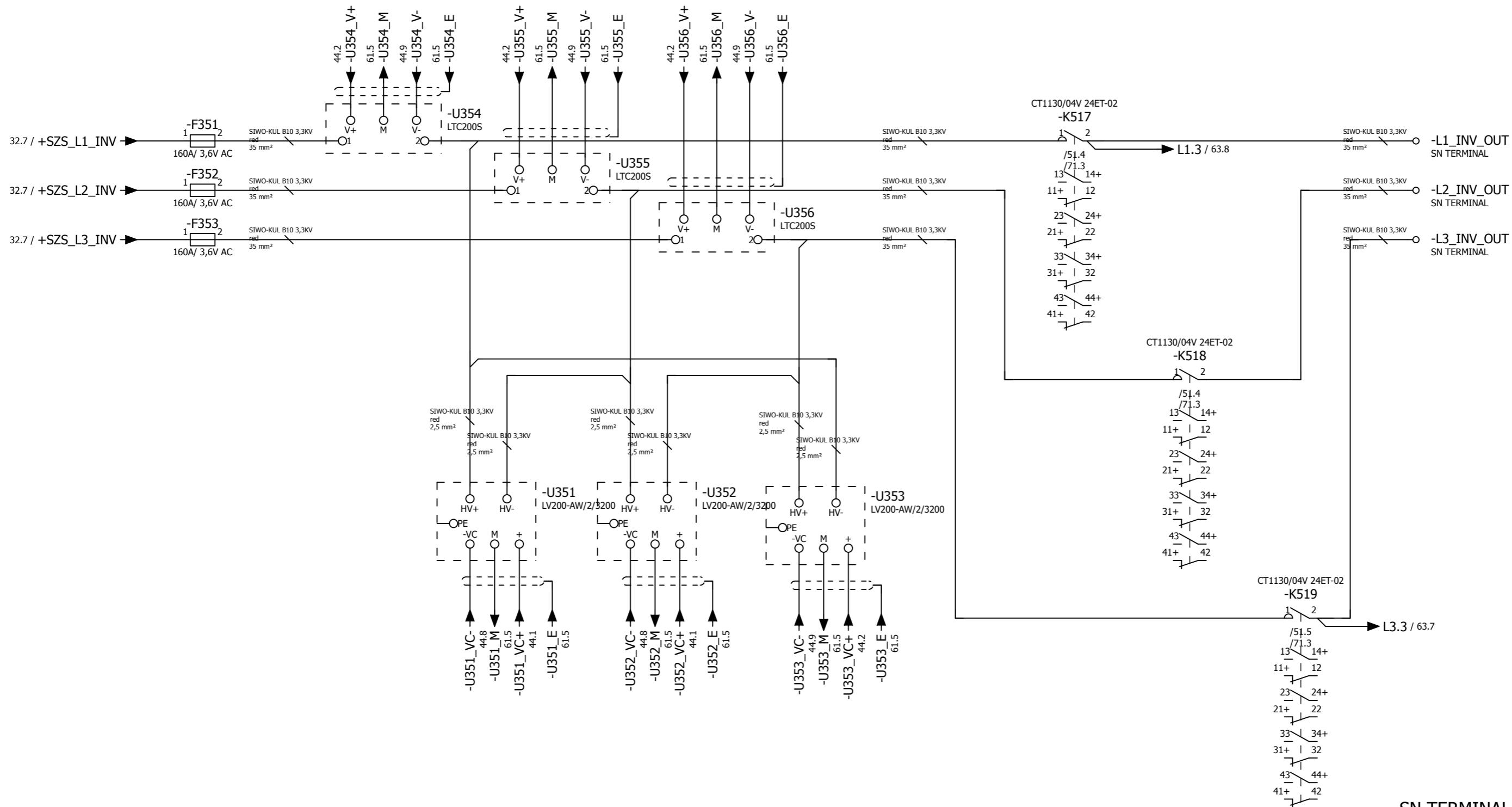

3 PHASE AC
MV OUTPUT

SN TERMINAL

TERMINALS HAVE TO BE MOUNTED ON THE ISOLATING PLATE
HOLES WITH PRESSNUTS





ABB SP. Z O. O. RESERVES ALL RIGHTS IN THIS DOCUMENT AND IN THE INFORMATION CONTAINED THEREIN. REPRODUCTION, USE OR DISCLOSURE TO THIRD PARTIES WITHOUT EXPRESS AUTHORITY IS STRICTLY FORBIDDEN.

			Date	2015-06-17	Laboratorium AGH		ABB sp. z o. o. Starowislna 13a 31-038 Krakow	Main circuit of SZS	Electrical diagrams		= AGH
			Edit	R.Zbien							+ SZS
			Check	M.Borkowski							
Change	Date	Name	Appr	W.Kolomyjski				Doc. no.		Page no.	35
										Pages	37

R361-R366 NOT MOUNTED
C361-C366 NOT MOUNTED

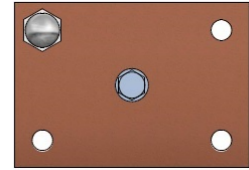
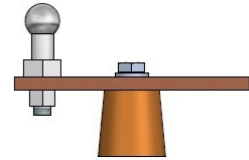



ABB SP. Z O. O. RESERVES ALL RIGHTS IN THIS DOCUMENT AND IN THE INFORMATION CONTAINED THEREIN. REPRODUCTION, USE OR DISCLOSURE TO THIRD PARTIES WITHOUT EXPRESS AUTHORITY IS STRICTLY FORBIDDEN.

			Date	2015-06-18	ABB	ABB sp. z o. o. Starowislna 13a 31-038 Krakow	Main DC circuit	Electrical diagrams		= AGH	
			Edit	R.Zbien						+ SZS	
			Check	M.Borkowski							
Change	Date	Name	Appr	W.Kolomyjski	Laboratorium AGH		Doc. no.			Page no.	36
										Pages	37

R371-R374 AND C371-C372 NOT MOUNTED

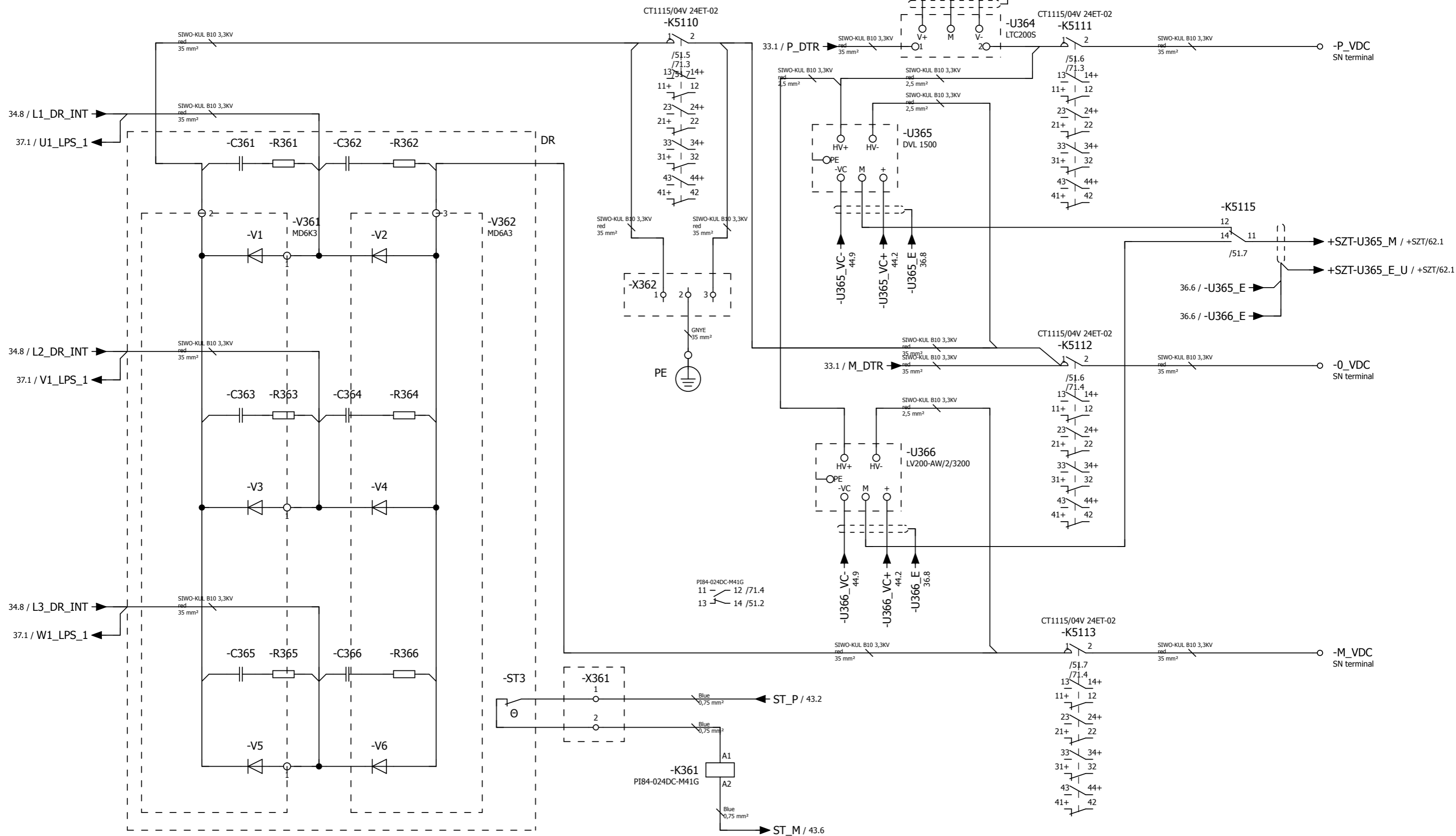
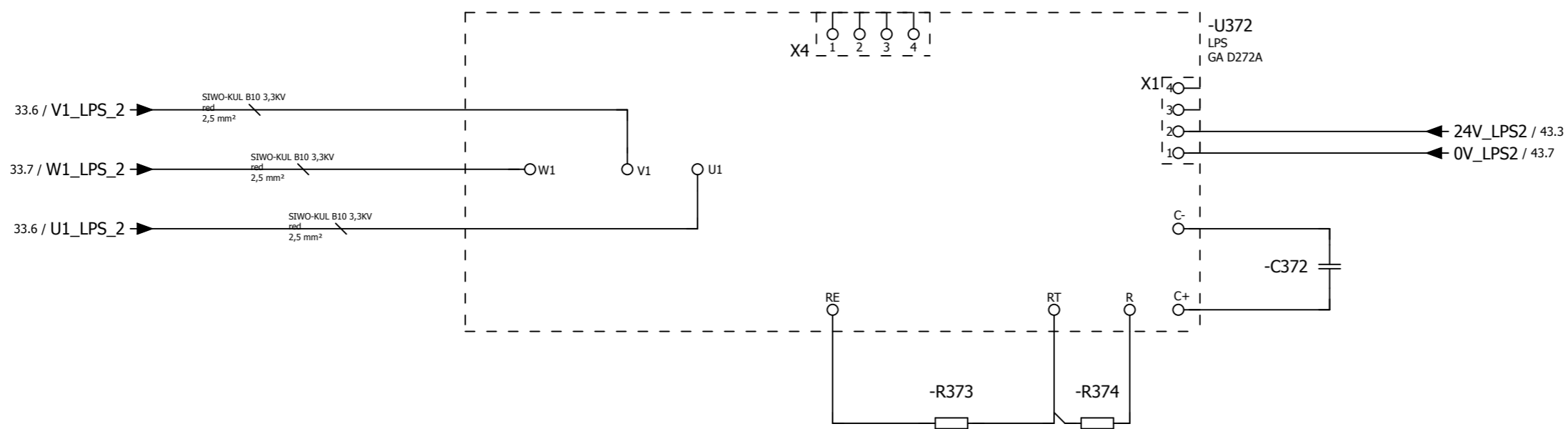
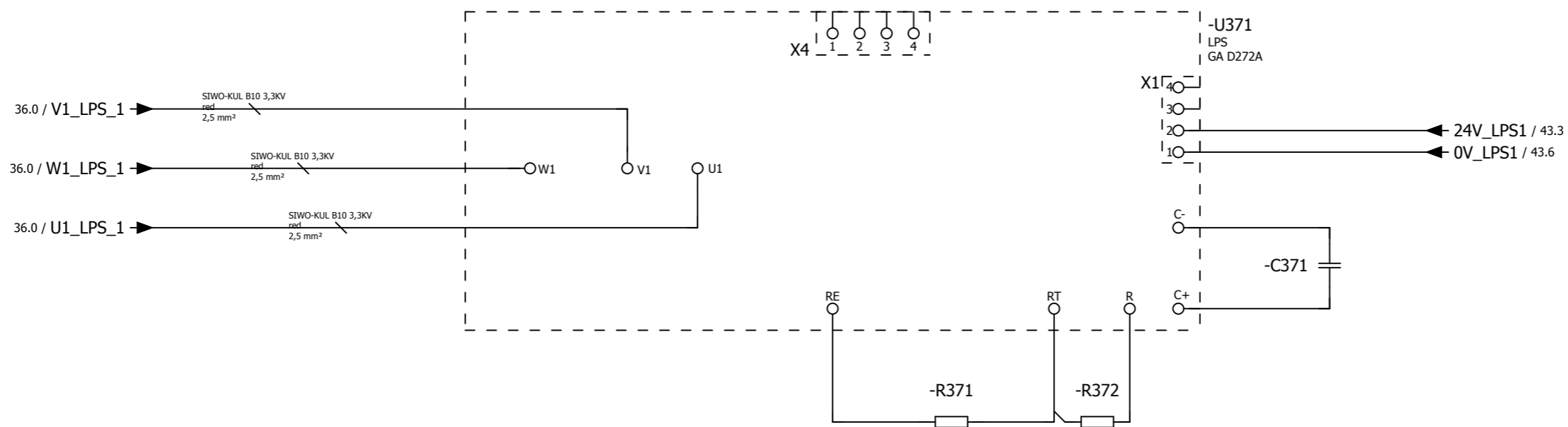

			Date	2015-06-18	Laboratorium AGH		ABB sp. z o. o. Starowislna 13a 31-038 Krakow	LPS Devices	Electrical diagrams		= AGH
			Edit	R.Zbien					+ SZS		
			Check	M.Borkowski							
Change	Date	Name	Appr	W.Kolomyjski				Doc. no.		Page no.	37
										Pages	37



ABB SP. Z O. O. RESERVES ALL RIGHTS IN THIS DOCUMENT AND IN THE INFORMATION CONTAINED THEREIN. REPRODUCTION, USE OR DISCLOSURE TO THIRD PARTIES WITHOUT EXPRESS AUTHORITY IS STRICTLY FORBIDDEN.

			Date	2015-06-16	Laboratorium AGH		ABB sp. z o. o. Starowislna 13a 31-038 Krakow	Auxiliary supply 230V	Electrical diagrams		= AGH
			Edit	R.Zbien					+ SZS		
			Check	M.Borkowski							
Change	Date	Name	Appr	W.Kolomyjski				Doc. no.		Page no.	42
										Pages	37

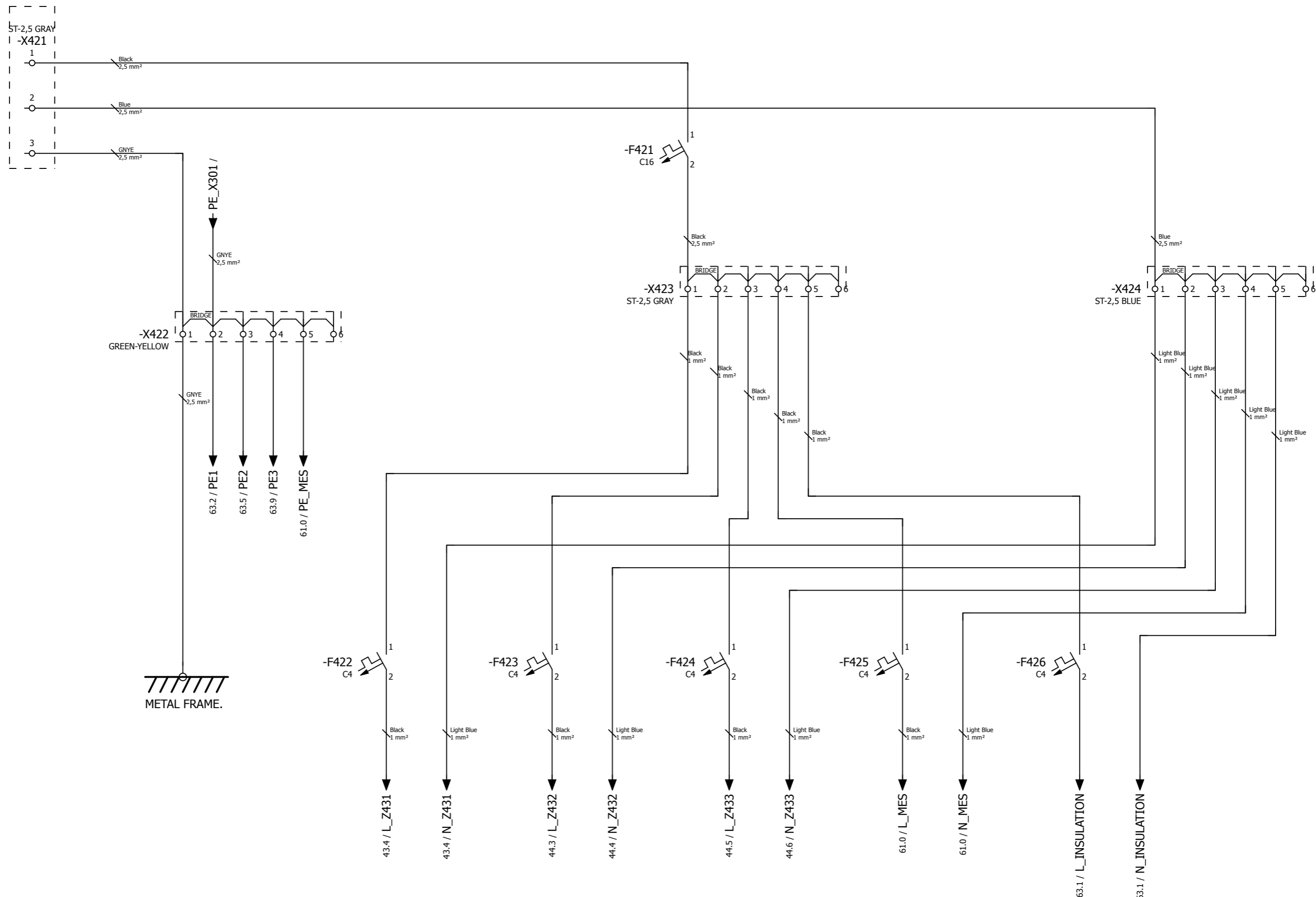

ABB SP. Z O. O. RESERVES ALL RIGHTS IN THIS DOCUMENT AND IN THE INFORMATION CONTAINED THEREIN. REPRODUCTION, USE OR DISCLOSURE TO THIRD PARTIES WITHOUT EXPRESS AUTHORITY IS STRICTLY FORBIDDEN.

			Date	2015-06-18	ABB	ABB sp. z o. o. Starowislna 13a 31-038 Krakow	Auxiliary supply 24V	Electrical diagrams		= AGH
			Edit	R.Zbien						+ SZS
			Check	M.Borkowski						
Change	Date	Name	Appr	W.Kolomyjski				Doc. no.		Page no. 43
									Pages 37	





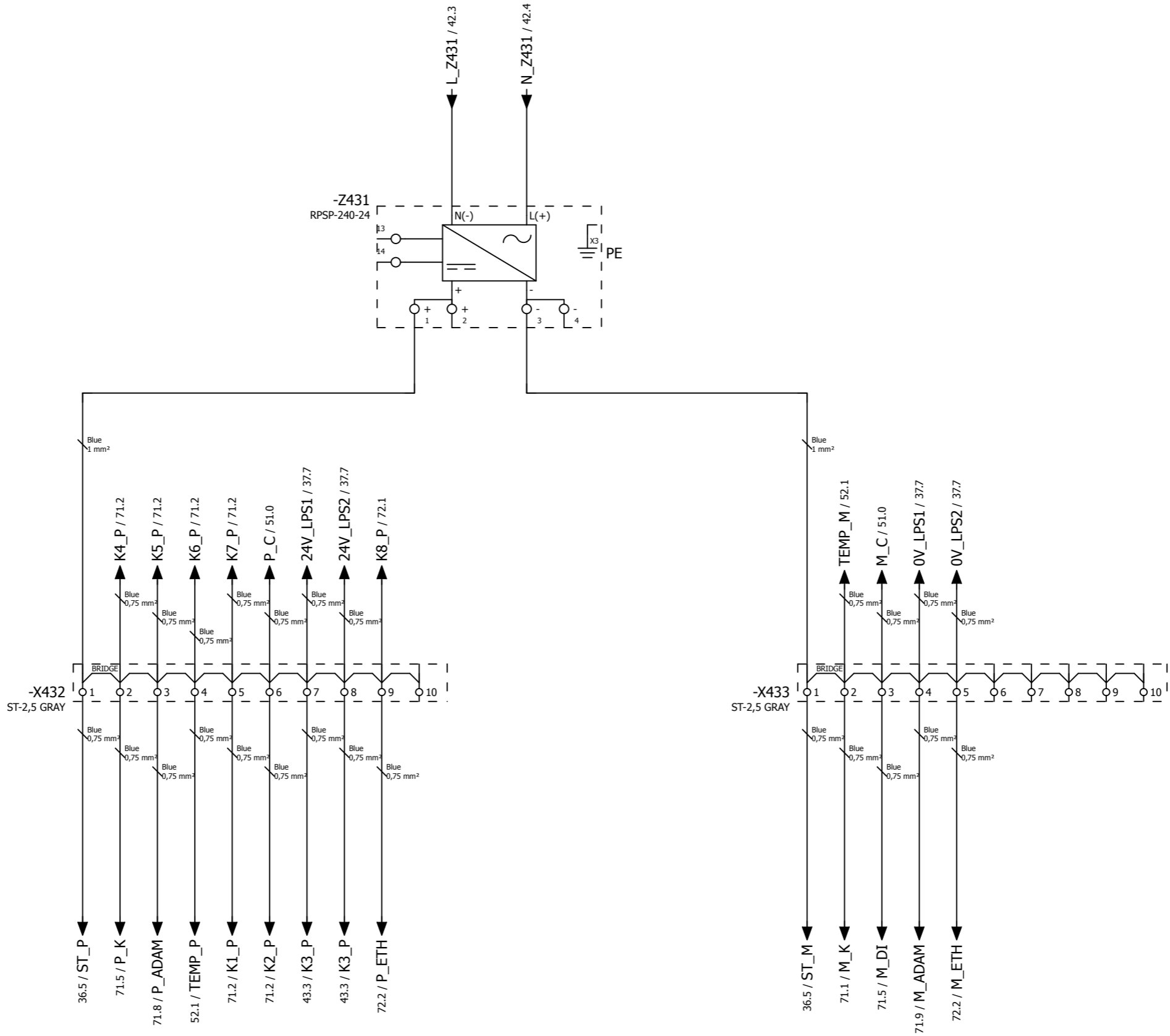

ABB SP. Z O. O. RESERVES ALL RIGHTS IN THIS DOCUMENT AND IN THE INFORMATION CONTAINED THEREIN. REPRODUCTION, USE OR DISCLOSURE TO THIRD PARTIES WITHOUT EXPRESS AUTHORITY IS STRICTLY FORBIDDEN.

			Date	2015-06-17	Laboratorium AGH		ABB sp. z o. o. Starowislna 13a 31-038 Krakow	Auxiliary supply 24V	Electrical diagrams		= AGH
			Edit	R.Zbien					+ SZS		
			Check	M.Borkowski							
Change	Date	Name	Appr	W.Kolomyjski					Doc. no.		Page no. 44
										Pages 37	

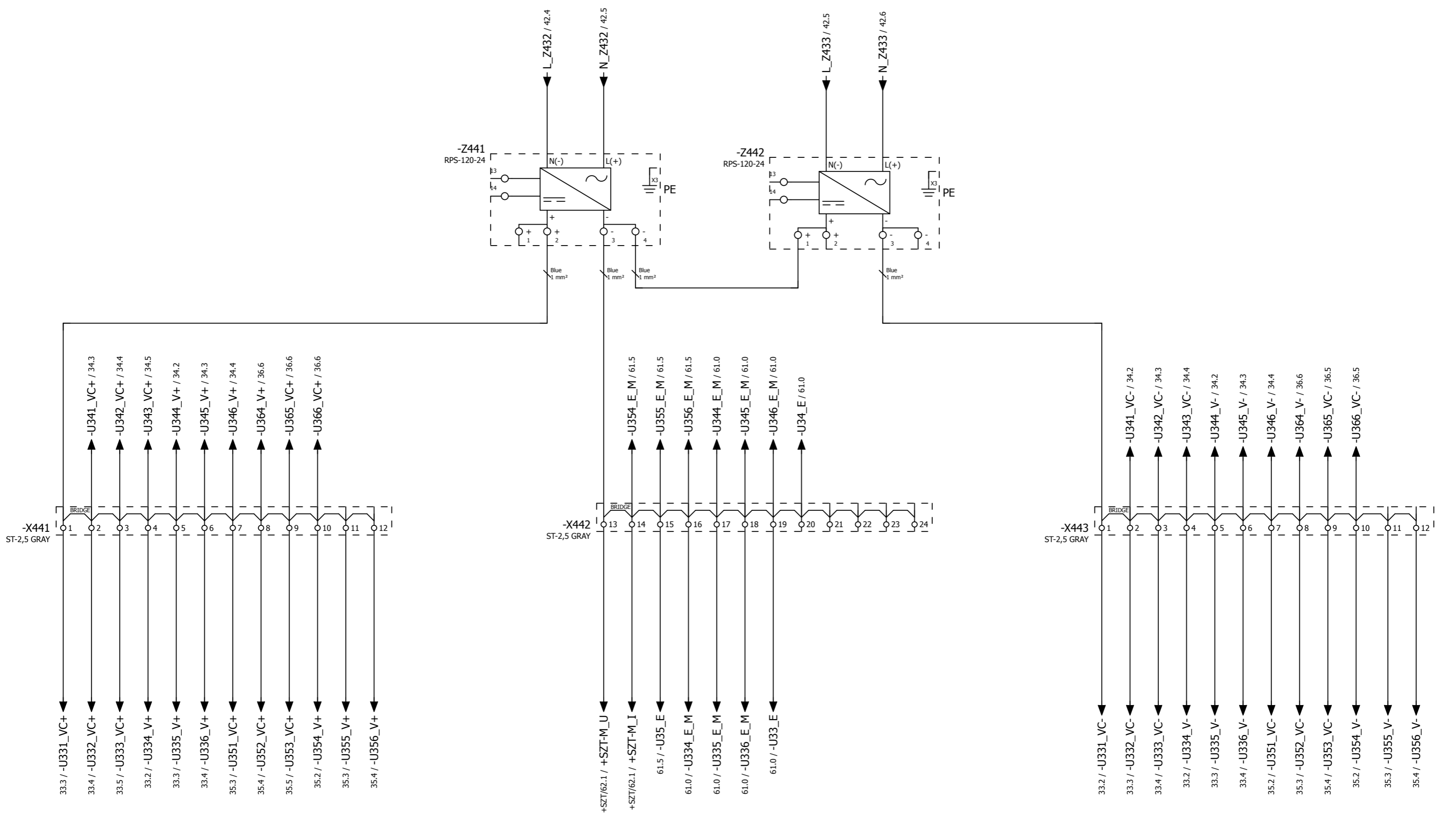

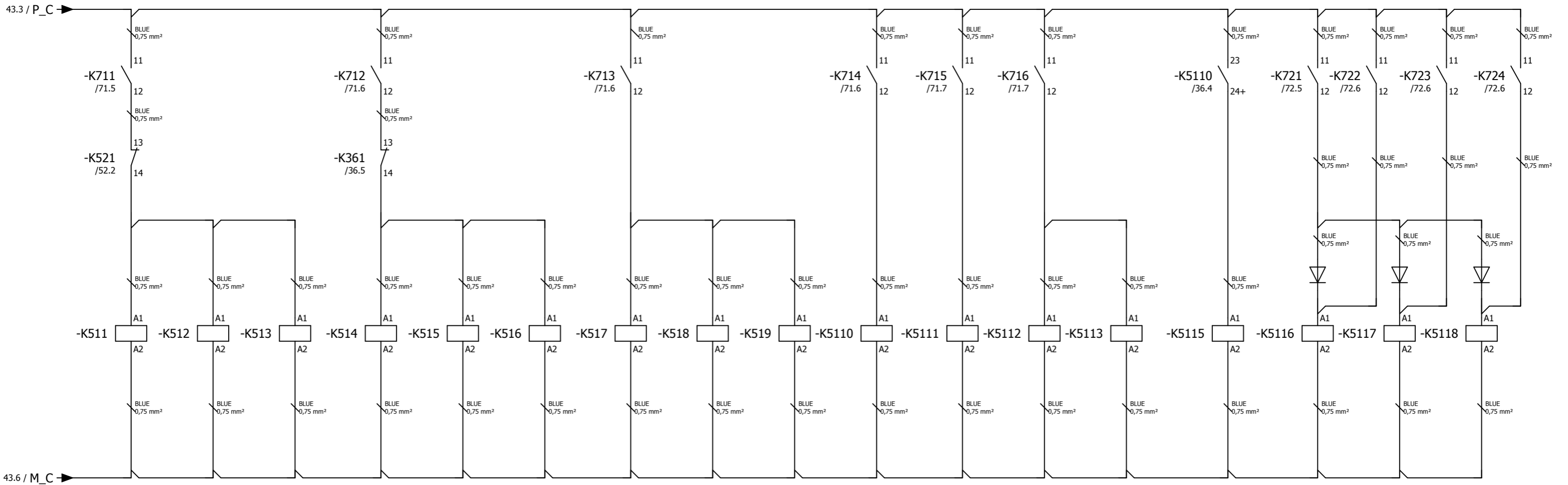
CT1115/04 V 24ET-02 CT1115/04 V 24ET-02 CT1115/04 V 24ET-02 CT1115/04 V 24ET-02 CT1115/04 V 24ET-02 CT1115/04 V 24ET-02 CT1130/04 V 24ET-02 CT1130/04 V 24ET-02 CT1130/04 V 24ET-02 CT1130/04 V 24ET-02 CT1130/04 V 24ET-02 CT1130/04 V 24ET-02 CT1130/04 V 24ET-02 PI84-024DC-M41G CH815 24ER-N1 CH815 24ER-N1 CH815 24ER-N1
 1 2 /33.6 1 2 /33.6 1 2 /33.6 1 2 /34.6 1 2 /34.7 1 2 /35.6 1 2 /35.7 1 2 /35.7 1 2 /36.4 1 2 /36.7 1 2 /36.7 1 2 /36.7 13 - 14+ /71.2 13 - 14+ /71.2 13 - 14+ /71.2 13 - 14+ /71.2 13 - 14+ /71.3 13 - 14+ /71.3 13 - 14+ /71.3 13 - 14+ /71.3 13 - 14+ /71.3 13 - 14+ /71.3 13 - 14+ /71.3 13 - 14+ /71.4 13 - 14+ /71.4 23 - 24+ .7 14 - 11 /36.8 13 - 14+ /72.2 13 - 14+ /72.2 13 - 14+ /72.3

Change	Date	Name	Appr	W.Kolomyjski	Laboratorium AGH	 ABB sp. z o. o. Starowislna 13a 31-038 Krakow	Conntactors	Electrical diagrams	= AGH	Page no. 51
									+ SZS	
Doc. no.										

INTERNAL EXTERNAL

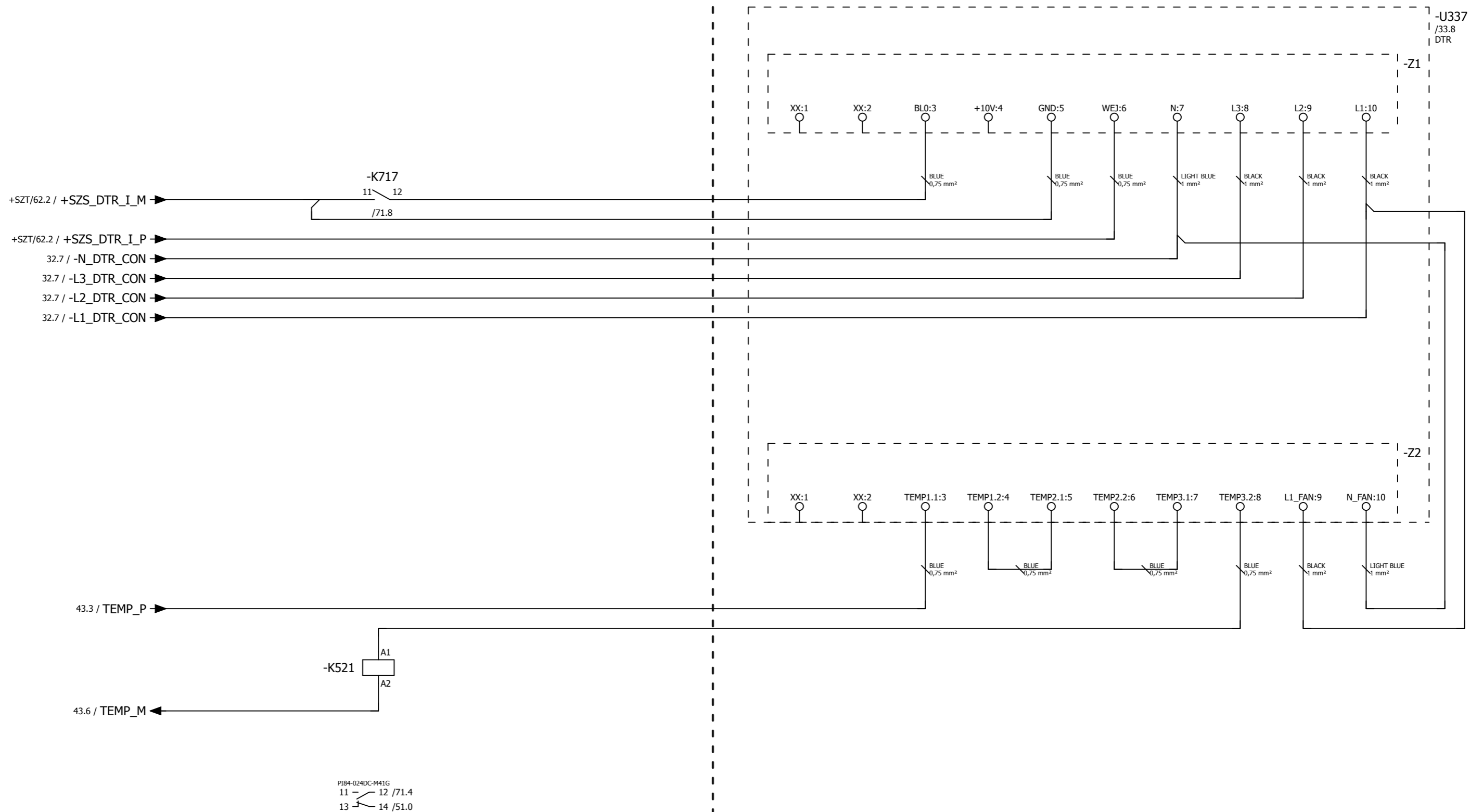

			Date	2015-06-17	Laboratorium AGH		ABB sp. z o. o. Starowislna 13a 31-038 Krakow	DTR Control	Electrical diagrams		= AGH		
			Edit	R.Zbien									+ SZS
			Check	M.Borkowski									
Change	Date	Name	Appr	W.Kolomyjski					Doc. no.				
										Page no.	52		
										Pages	37		

R611-R6119 NOT MOUNTED



ABB SP. Z O. O. RESERVES ALL RIGHTS IN THIS DOCUMENT AND IN THE INFORMATION CONTAINED THEREIN. REPRODUCTION, USE OR DISCLOSURE TO THIRD PARTIES WITHOUT EXPRESS AUTHORITY IS STRICTLY FORBIDDEN.

			Date	2015-06-17	Laboratorium AGH		ABB sp. z o. o. Starowislna 13a 31-038 Krakow	Door	Electrical diagrams		= AGH
			Edit	R.Zbien							+ SZS
			Check	M.Borkowski							
Change	Date	Name	Appr	W.Kolomyjski				Doc. no.		Page no.	61
										Pages	37

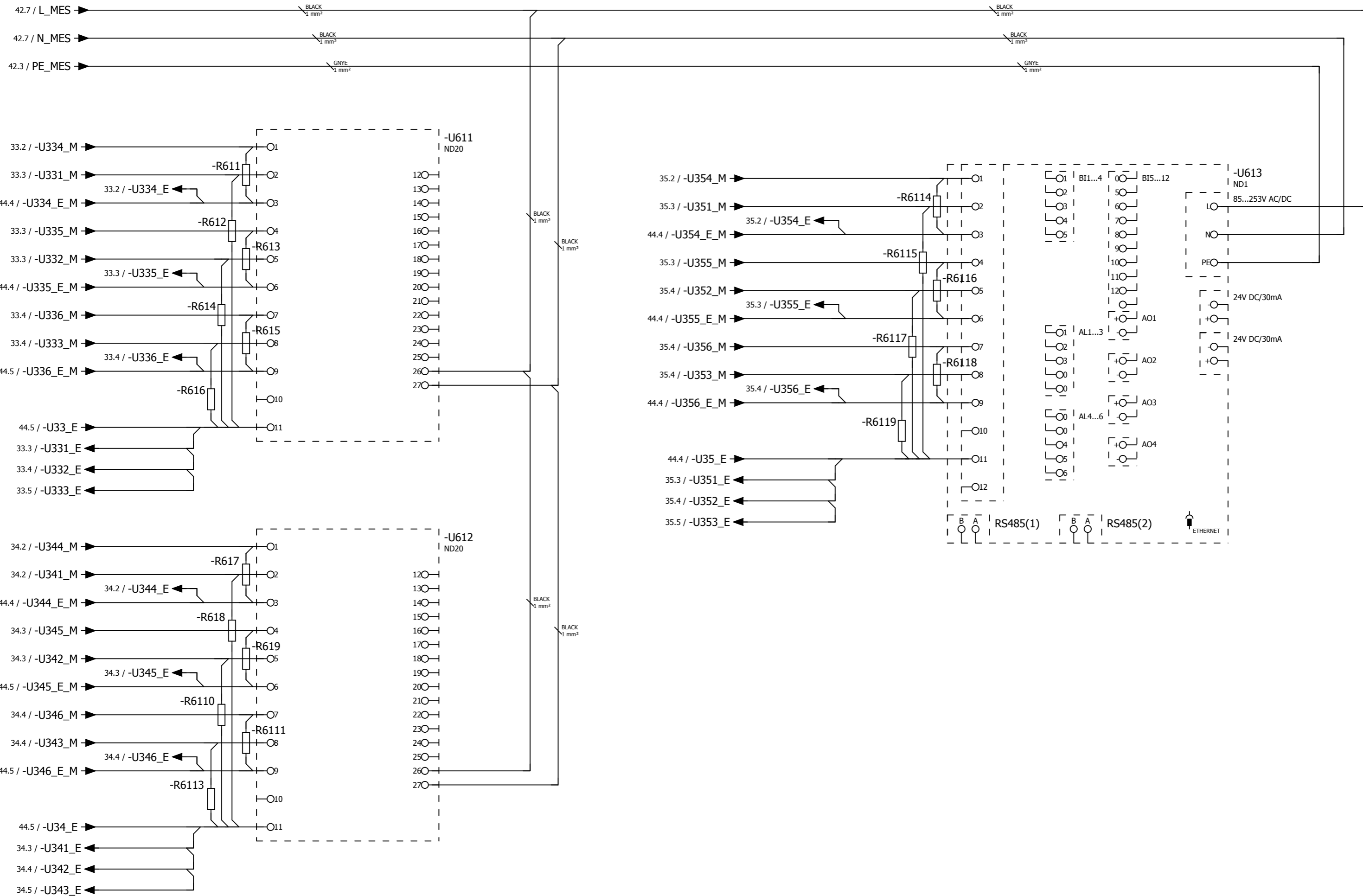

ABB SP. Z O. O. RESERVES ALL RIGHTS IN THIS DOCUMENT AND IN THE INFORMATION CONTAINED THEREIN. REPRODUCTION, USE OR DISCLOSURE TO THIRD PARTIES WITHOUT EXPRESS AUTHORITY IS STRICTLY FORBIDDEN.

			Date	2015-06-16	Laboratorium AGH		ABB sp. z o. o. Starowislna 13a 31-038 Krakow	Insulation control	Electrical diagrams		= AGH
			Edit	R.Zbien							+ SZS
			Check	M.Borkowski							
Change	Date	Name	Appr	W.Kolomyjski				Doc. no.		Page no.	63
										Pages	37

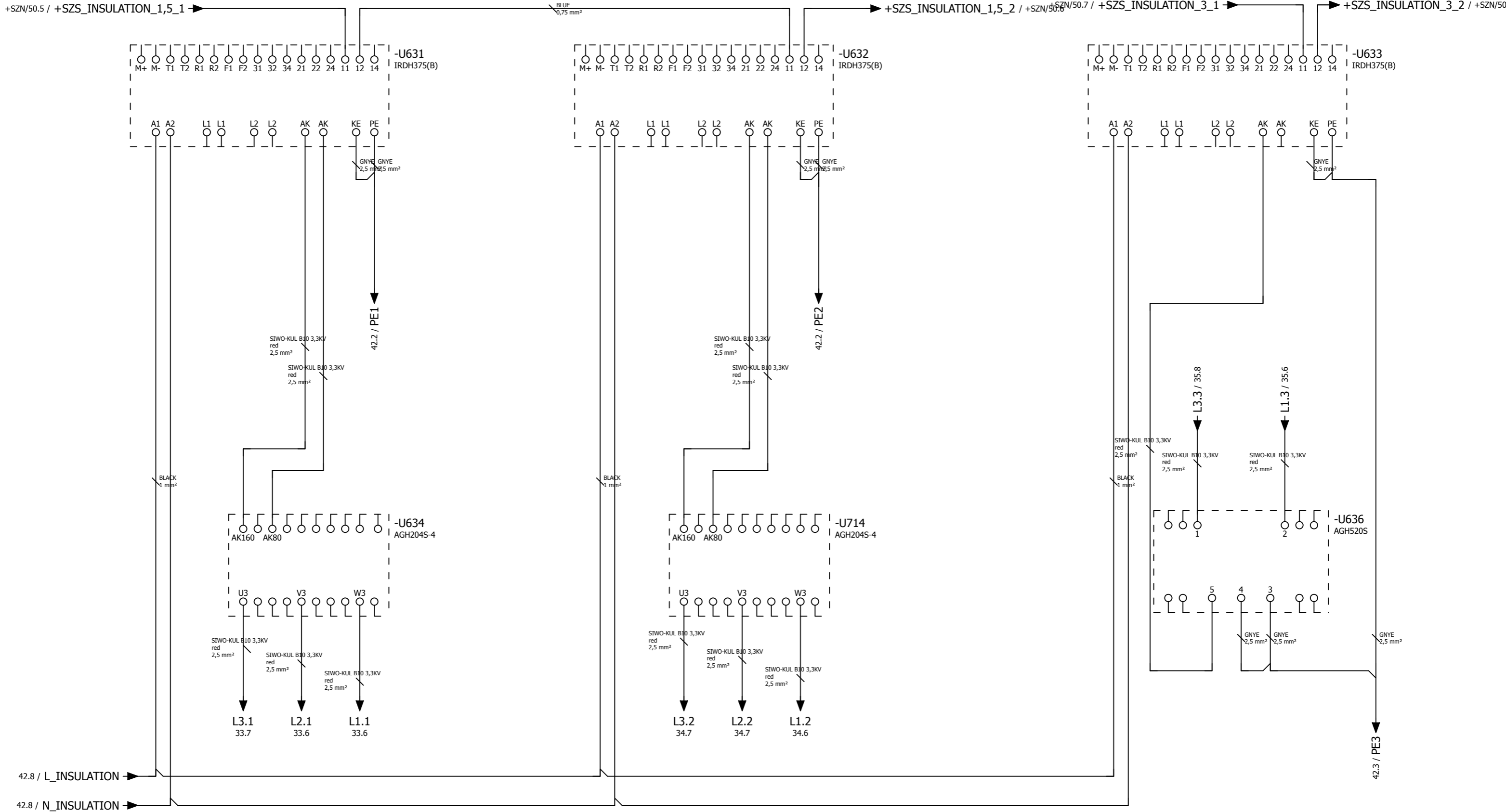

ABB SP. Z O. O. RESERVES ALL RIGHTS IN THIS DOCUMENT AND IN THE INFORMATION CONTAINED THEREIN. REPRODUCTION, USE OR DISCLOSURE TO THIRD PARTIES WITHOUT EXPRESS AUTHORITY IS STRICTLY FORBIDDEN.

				Date	2015-06-18	Laboratorium AGH		ABB sp. z o. o. Starowislna 13a 31-038 Krakow	Digital I/O	Electrical diagrams		= AGH
				Edit	R.Zbien					+ SZS		
				Check	M.Borkowski							
Change	Date	Name	Appr	W.Kolomyjski					Doc. no.		Page no.	71
											Pages	37

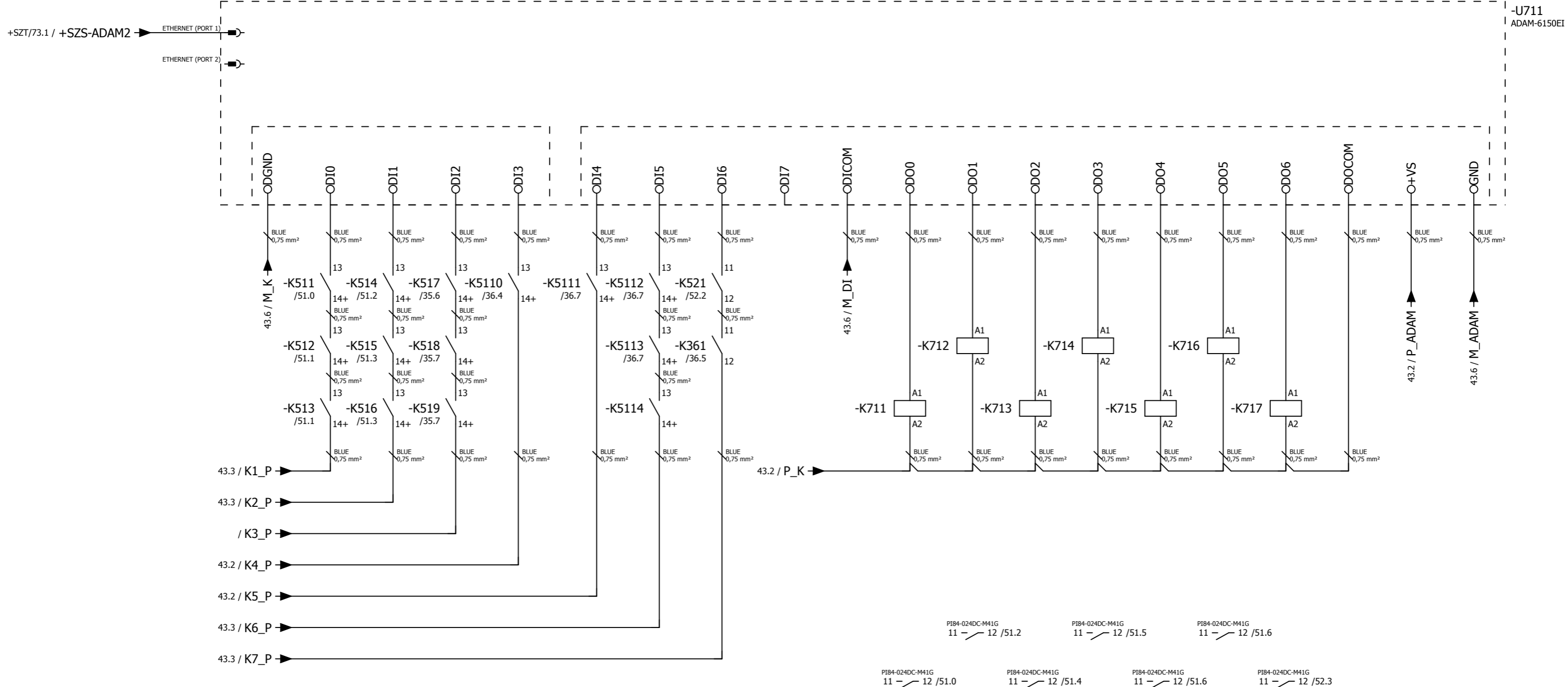
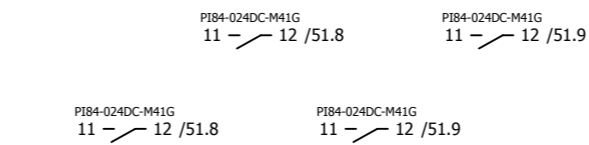
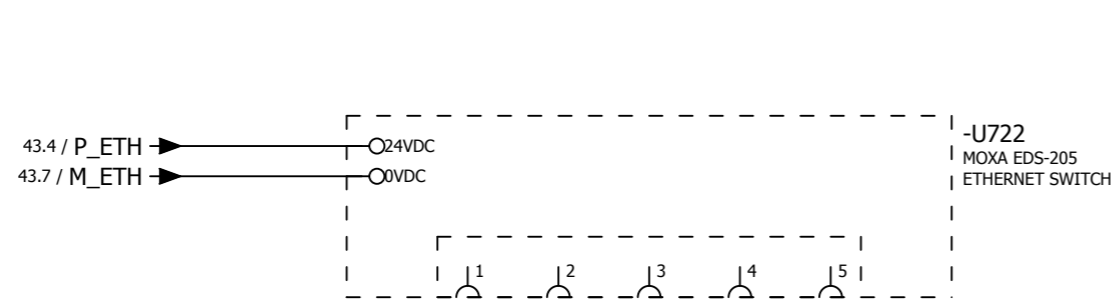
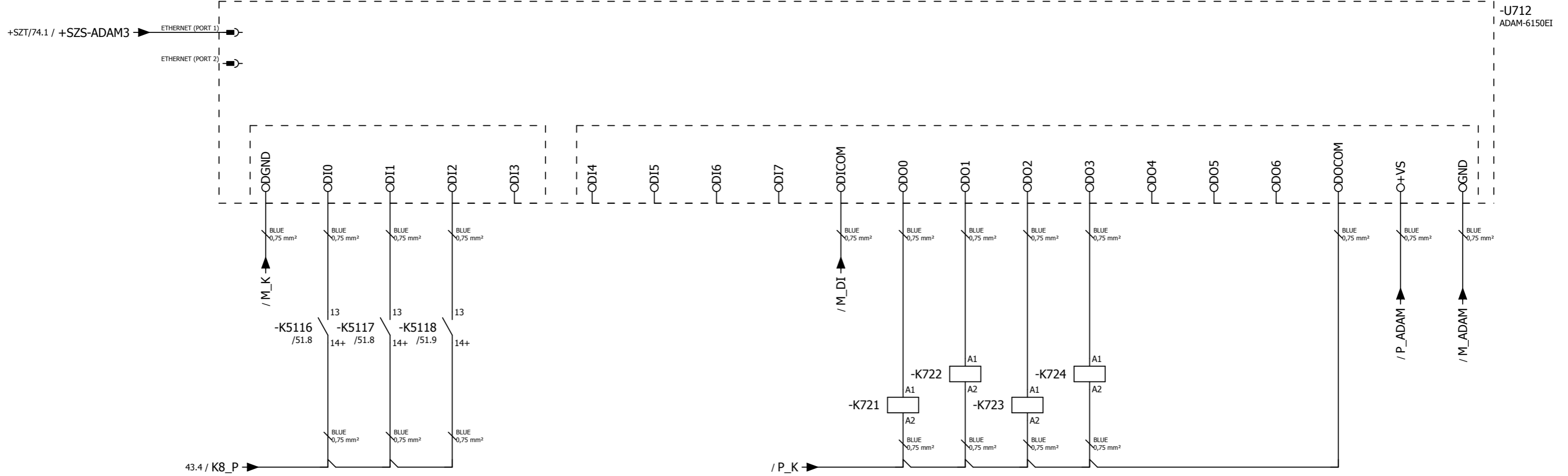

ABB SP. Z O. O. RESERVES ALL RIGHTS IN THIS DOCUMENT AND IN THE INFORMATION CONTAINED THEREIN. REPRODUCTION, USE OR DISCLOSURE TO THIRD PARTIES WITHOUT EXPRESS AUTHORITY IS STRICTLY FORBIDDEN.

			Date	2015-06-18	Laboratorium AGH		ABB sp. z o. o. Starowislna 13a 31-038 Krakow	Digital I/O	Electrical diagrams		= AGH		
			Edit	R.Zbien									+ SZS
			Check	M.Borkowski									
Change	Date	Name	Appr	W.Kolomyjski					Doc. no.				
										Page no.	72		
										Pages	37		