



ABB Sp. z o.o.
ul. Starowińska 13a
31-038 Krakow

Project description : Laboratorium AGH

Project number :

Performer : ABB sp. z o. o.

Project name : Laboratorium AGH

			Date	2015-02-26	Laboratorium AGH		ABB sp. z o. o. Starowislna 13a 31-038 Krakow	Strona tytułowa szafa CM	Electrical diagrams	= AGH	Page no. 3	
			Edit	R.Zbien						+ SZT		Pages 37
Change	Date	Name	Appr	W.Kolomyjski								



ABB SP. Z O. O. RESERVES ALL RIGHTS IN THIS DOCUMENT AND IN THE INFORMATION CONTAINED THEREIN. REPRODUCTION, USE OR DISCLOSURE TO THIRD PARTIES WITHOUT EXPRESS AUTHORITY IS STRICTLY FORBIDDEN.

				Laboratorium AGH			ABB sp. z o. o. Starowislna 13a 31-038 Krakow		Auxiliary supply		Electrical diagrams		= AGH	
Change	Date	Name	Appr	W.Kolomyjski						Doc. no.		Page no. 45		
												Pages 37		

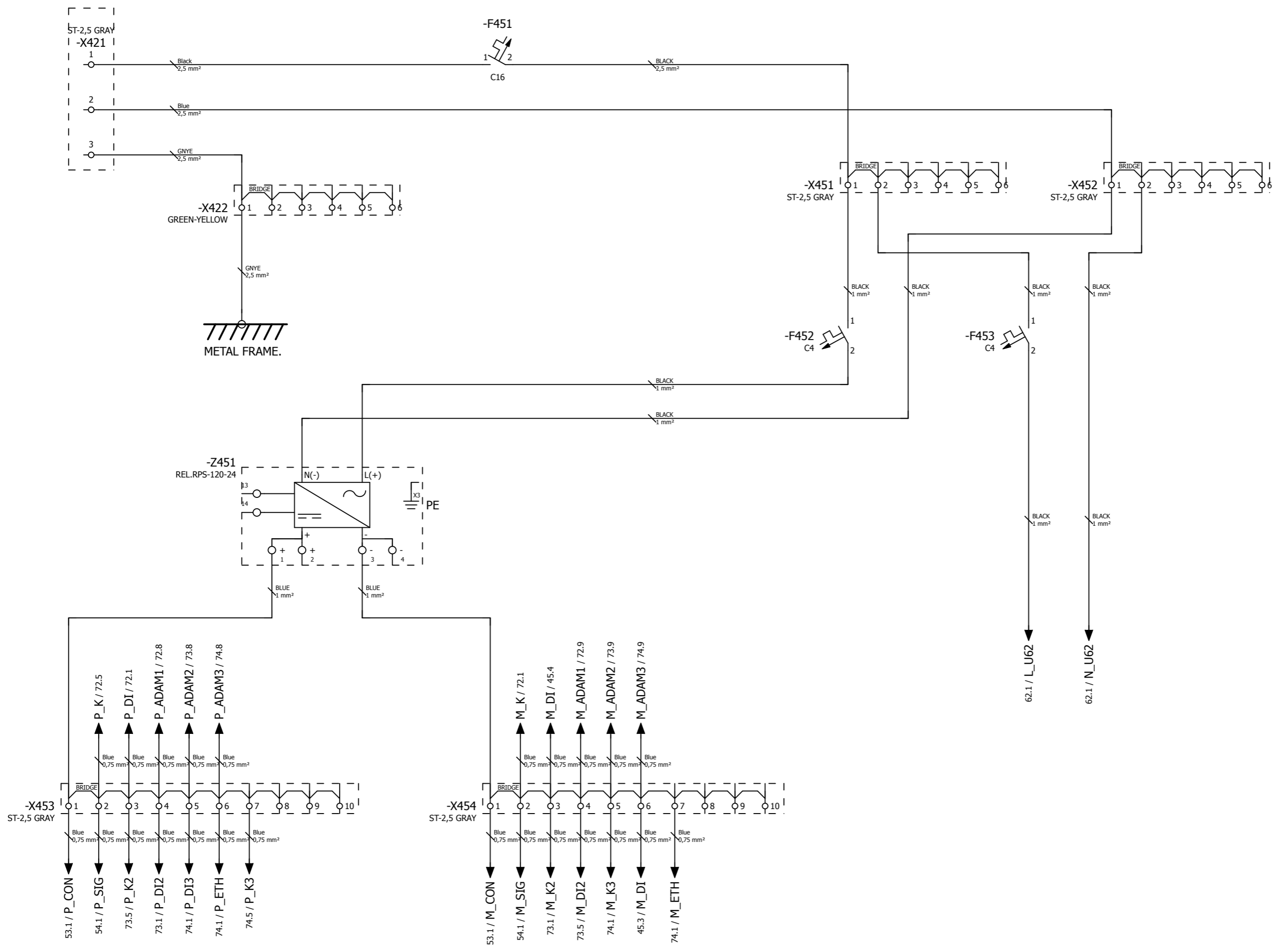
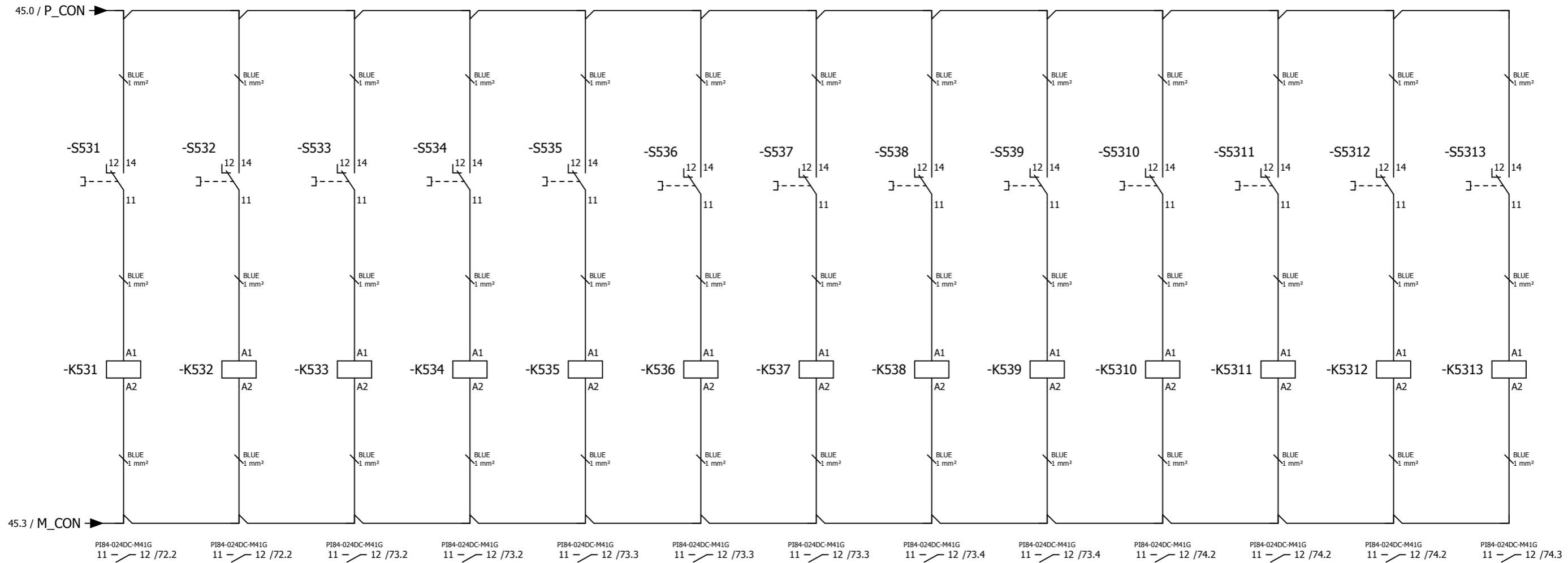

CONTACTOR Q1

CONTACTOR Q2

CONTACTOR K1

CONTACTOR K2

CONTACTOR K3

CONTACTOR K4

CONTACTOR K5

CONTACTOR K6

DTR BLOCK

RO Contactors

RO Contactor 1

RO Contactor 2

RO Contactor 3

ABB SP. Z O. O. RESERVES ALL RIGHTS IN THIS DOCUMENT AND IN THE INFORMATION CONTAINED THEREIN. REPRODUCTION, USE OR DISCLOSURE TO THIRD PARTIES WITHOUT EXPRESS AUTHORITY IS STRICTLY FORBIDDEN.

			Date	2015-06-18	Laboratorium AGH		ABB sp. z o. o. Starowislna 13a 31-038 Krakow	Control	Electrical diagrams		= AGH
			Edit	R.Zbien							+ SZT
			Check	M.Borkowski							
Change	Date	Name	Appr	W.Kolomyjski				Doc. no.			Page no. 53
											Pages 37

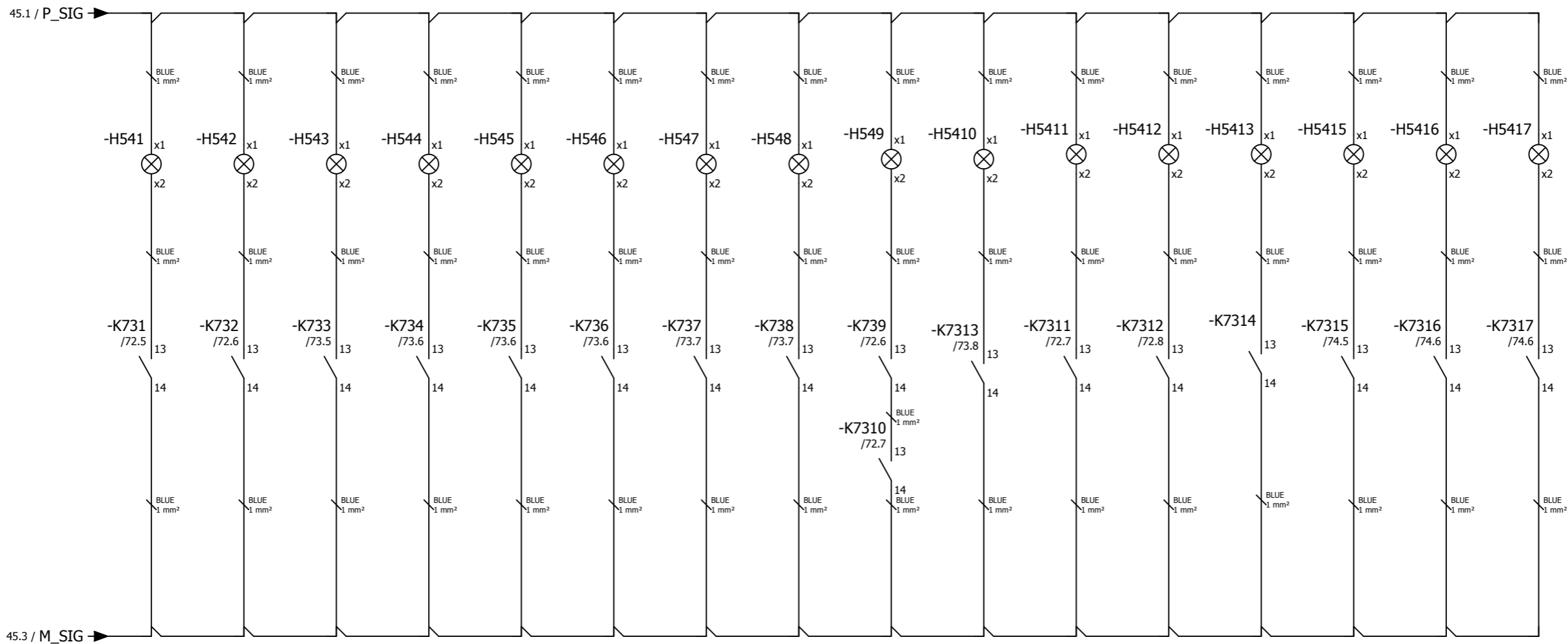

- CONNTACTOR Q1 ON
- CONNTACTOR Q2 ON
- CONNTACTOR K1 ON
- CONNTACTOR K2 ON
- CONNTACTOR K3 ON
- CONNTACTOR K4 ON
- CONNTACTOR K5 ON
- CONNTACTOR K6 ON
- FUSES SZN OK
- TEMPERATURE DTR DR
- TEMPERATURE T1 OK
- TEMPERATURE T2 OK
- THYRISTOR RECTIFIER OK
- RO Contactor 1 ON
- RO Contactor 2 ON
- RO Contactor 3 ON

ABB SP. Z O. O. RESERVES ALL RIGHTS IN THIS DOCUMENT AND IN THE INFORMATION CONTAINED THEREIN. REPRODUCTION, USE OR DISCLOSURE TO THIRD PARTIES WITHOUT EXPRESS AUTHORITY IS STRICTLY FORBIDDEN.

			Date	2015-06-18		ABB sp. z o. o. Starowislna 13a 31-038 Krakow	Signalization	Electrical diagrams		= AGH			
			Edit	R.Zbien				Laboratorium AGH		Doc. no.		+ SZT	
			Check	M.Borkowski									Page no. 54
Change	Date	Name	Appr	W.Kolomyjski							Pages 37		

R621-R623 NOT MOUNTED

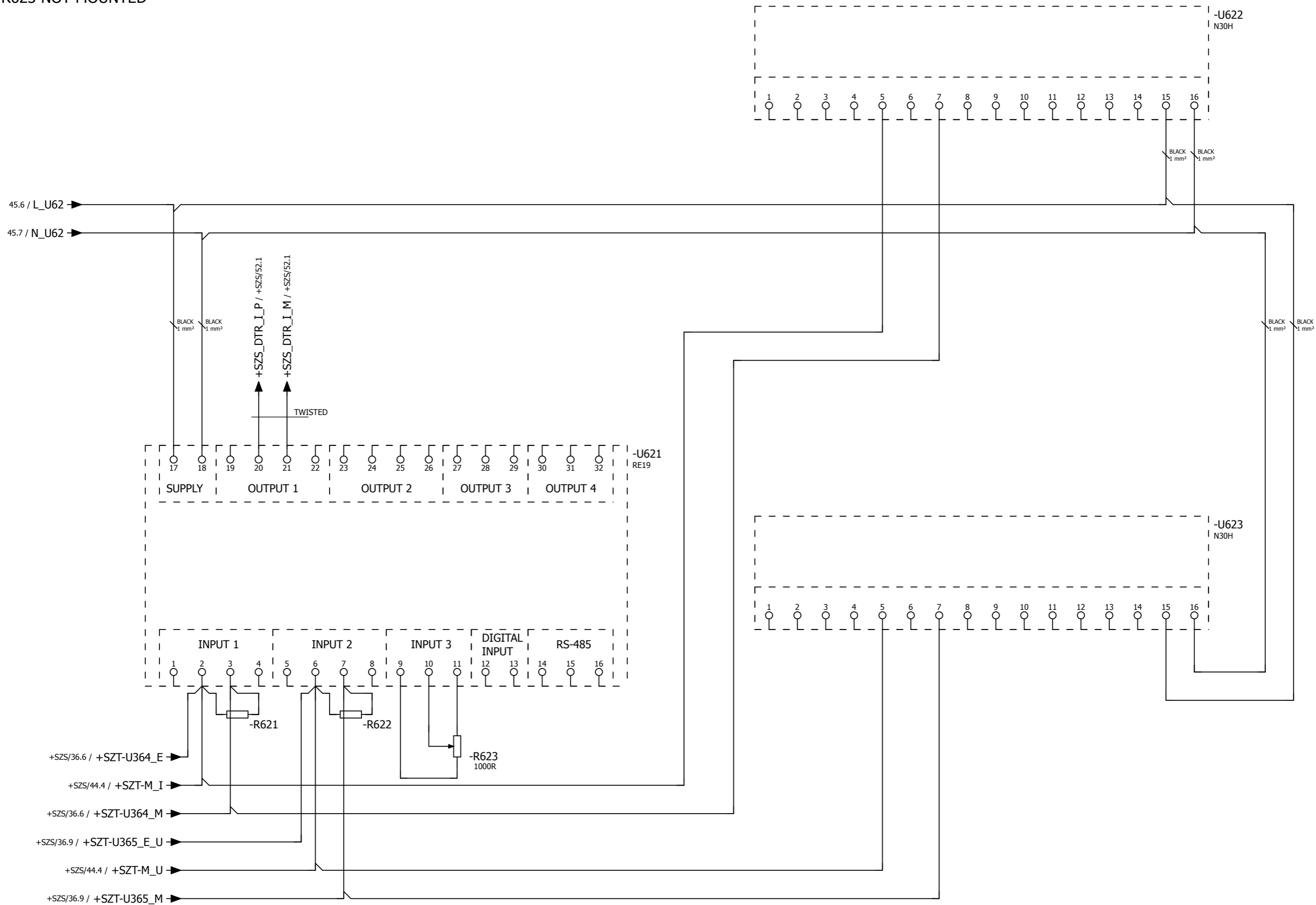

			Date	2015-06-18	Laboratorium AGH		ABB sp. z o. o. Starowislna 13a 31-038 Krakow	Measurement	Electrical diagrams		= AGH
			Edit	R.Zbien							+ SZT
			Check	M.Borkowski							
Change	Date	Name	Appr	W.Kolomyjski				Doc. no.		Page no.	62
										Pages	37

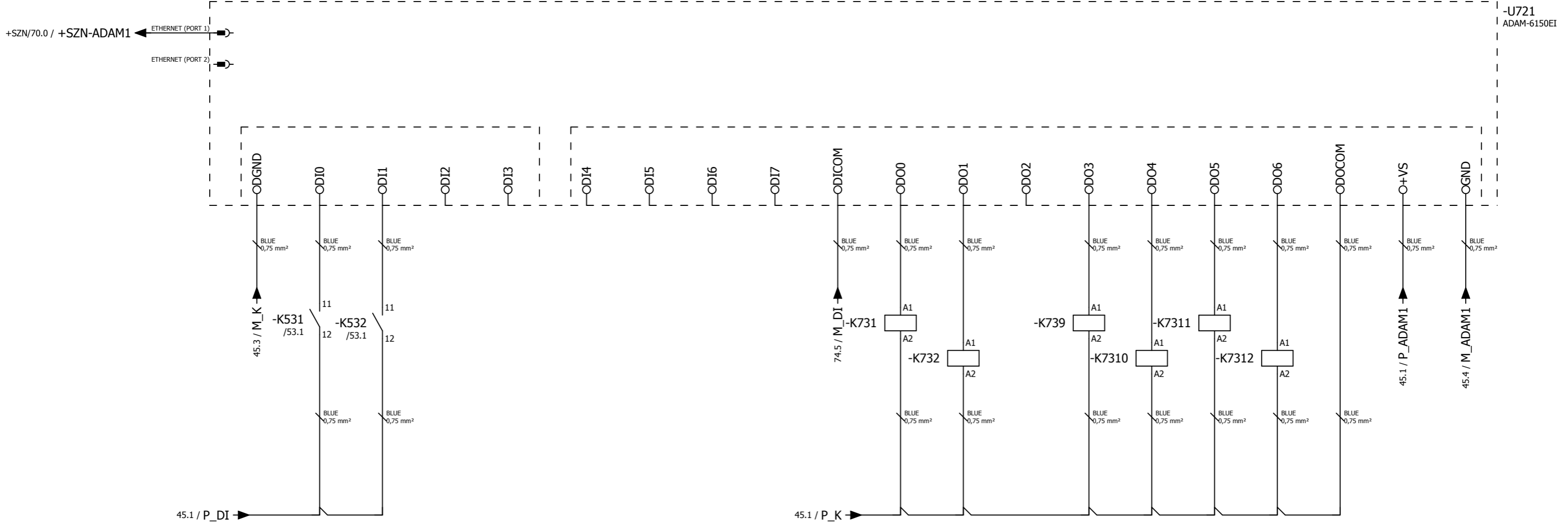

PI84-024DC-M41G 13 - 14 /54.1
 PI84-024DC-M41G 13 - 14 /54.2
 PI84-024DC-M41G 13 - 14 /54.5
 PI84-024DC-M41G 13 - 14 /54.5
 PI84-024DC-M41G 13 - 14 /54.6
 PI84-024DC-M41G 13 - 14 /54.6

ABB SP. Z O. O. RESERVES ALL RIGHTS IN THIS DOCUMENT AND IN THE INFORMATION CONTAINED THEREIN. REPRODUCTION, USE OR DISCLOSURE TO THIRD PARTIES WITHOUT EXPRESS AUTHORITY IS STRICTLY FORBIDDEN.

			Date	2015-06-18	Laboratorium AGH		ABB sp. z o. o. Starowislna 13a 31-038 Krakow	Digital I/O	Electrical diagrams		= AGH
			Edit	R.Zbien					+ SZT		
			Check	M.Borkowski							
Change	Date	Name	Appr	W.Kolomyjski				Doc. no.		Page no.	72
										Pages	37





ABB SP. Z O. O. RESERVES ALL RIGHTS IN THIS DOCUMENT AND IN THE INFORMATION CONTAINED THEREIN. REPRODUCTION, USE OR DISCLOSURE TO THIRD PARTIES WITHOUT EXPRESS AUTHORITY IS STRICTLY FORBIDDEN.

			Date	2015-06-18	Laboratorium AGH		ABB sp. z o. o. Starowislna 13a 31-038 Krakow	Digital I/O	Electrical diagrams		= AGH
			Edit	R.Zbien					+ SZT		
			Check	M.Borkowski							
Change	Date	Name	Appr	W.Kolomyjski				Doc. no.		Page no.	73
										Pages	37

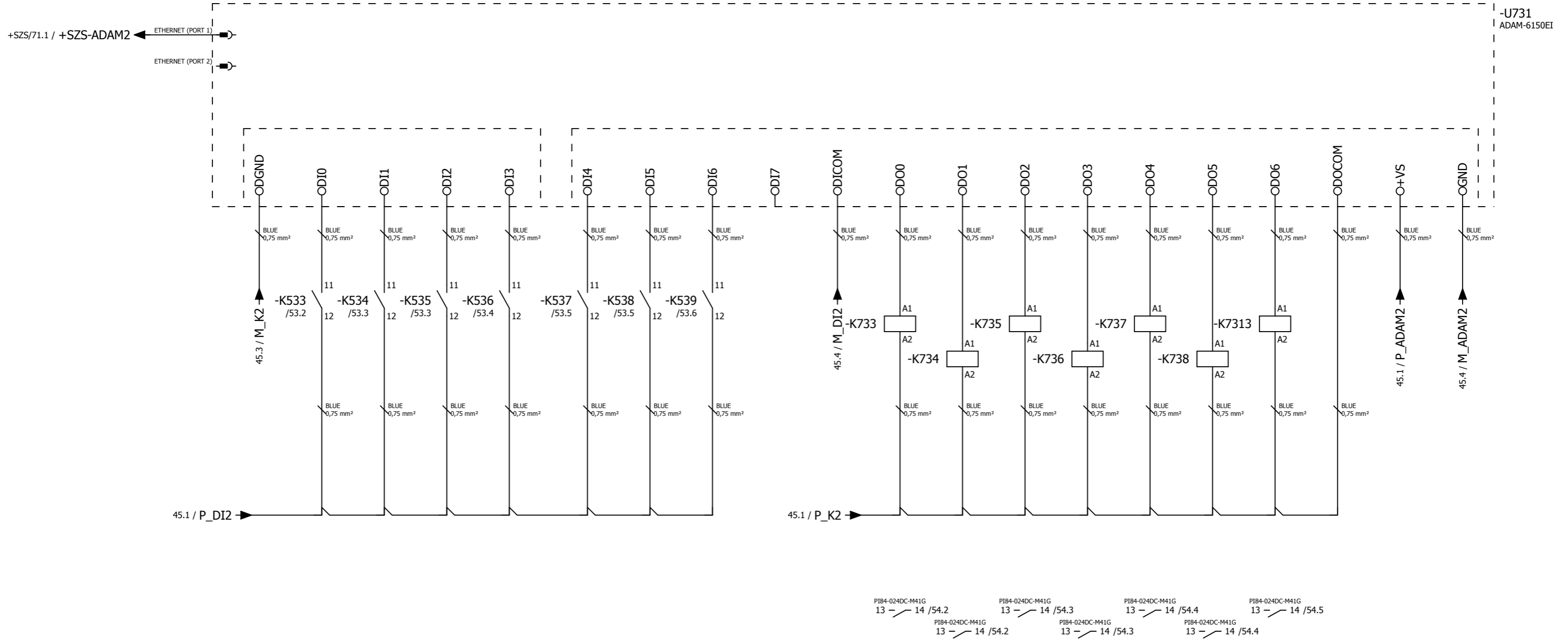
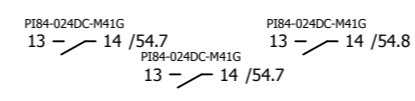
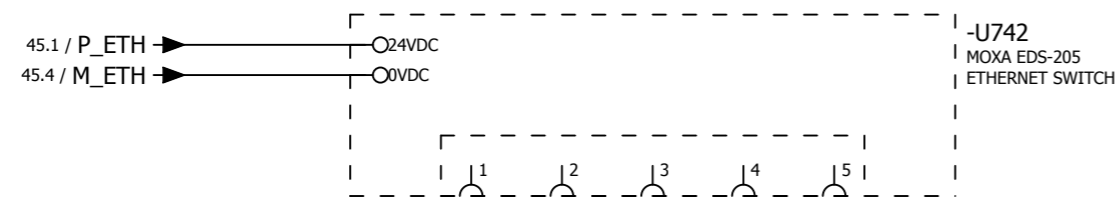
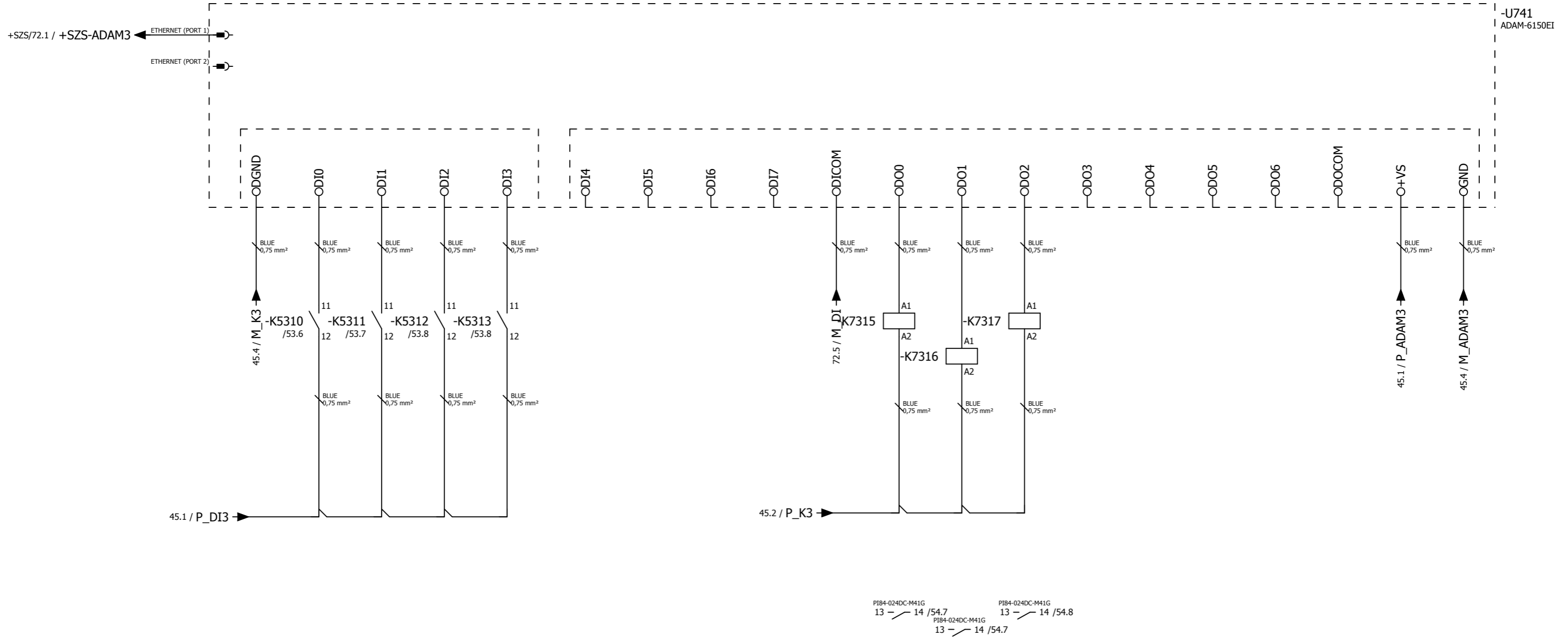

ABB SP. Z O. O. RESERVES ALL RIGHTS IN THIS DOCUMENT AND IN THE INFORMATION CONTAINED THEREIN. REPRODUCTION, USE OR DISCLOSURE TO THIRD PARTIES WITHOUT EXPRESS AUTHORITY IS STRICTLY FORBIDDEN.

			Date	2015-06-18	Laboratorium AGH		ABB sp. z o. o. Starowislna 13a 31-038 Krakow	Digital I/O	Electrical diagrams		= AGH		
			Edit	R.Zbien									+ SZT
			Check	M.Borkowski									
Change	Date	Name	Appr	W.Kolomyjski					Doc. no.		Page no. 74		
										Pages 37			