

Non-Metallic Systems

ATS - Type A - Yellow Elastomer



Technical Characteristics

Conforms to	BSI Kitemark KM-35161 CE Low voltage directive Lloyd's Register of Shipping (Type Approval) NF 16-10/12 I4, F2 CEI 11170 LR3 / LR4
-------------	--

Approvals and Standards	    
-------------------------	--

Degree of mechanical protection	High Impact Resistance
---------------------------------	------------------------

Degree of protection	IP66 - As standard IP67 - As standard IP68 - As Standard (4 bar 30 mins) IP69k - As standard
----------------------	---

UV protection	Very High
---------------	-----------

Fitting Characteristics	Straight single piece fitting - Integrated Seal System Fixed external male thread (Locknut supplied with METRIC threads only)
-------------------------	---

Application	For insertion into threaded entries knockouts using a locknut to secure
-------------	---

Normal operating temperature range	Application	Min Temp	Max Temp
	Static	- 50°C	+120°C
	Dynamic	- 45°C	+120 °C

For use with - Conduit Series	Light, Standard and Heavyweight variants of type PA , PI , PR , PADL & PF
-------------------------------	---

Fire performance	Test Standard	Performance Rating	
	BS EN 61386-1 & 23	Approved	
	NFF16-101	I4 F2	Self Extinguishing Low Smoke & Halogen Free
	ISO 4589-2	24%	
	BS EN 60695-2-11	850°C	
	UL94	HB	

Testing data	Click or See pages 5 & 6
--------------	--

Type of material	Polyamide (Nylon) 66 body, TPE Seal.
------------------	--------------------------------------



The Company's policy is one of continuous improvement and reserves the right to change specifications at any time without prior notice.

Non-Metallic Systems

ATS - Type A - Yellow Elastomer



Dimensional & Thread Data

Part No Black Body Metric Threads	Part No Grey Body Metric Threads	Thread A	Nominal Dimensions (mm)			
			B	C	D	E
AT13/M16/A/BLY	AT13/M16/A/GRY	M16x1.5	21.2	34.2	21.2	11.2
AT16/M16/A/BLY	AT16/M16/A/GRY	M16x1.5	11.8	36.0	23.2	11.2
AT16/M20/A/BLY	AT16/M20/A/GRY	M20x1.5	11.8	36.0	23.2	15.2
AT21/M20/A/BLY	AT21/M20/A/GRY	M20x1.5	11.8	36.5	30.2	15.2
AT21/M25/A/BLY	AT21/M25/A/GRY	M25x1.5	11.8	39.3	3.02	20.0
AT28/M25/A/BLY	AT28/M25/A/GRY	M25x1.5	15.8	39.3	37.2	20.0
AT28/M32/A/BLY	AT28/M32/A/GRY	M32x1.5	15.8	39.3	37.2	26.7
AT34/M32/A/BLY	AT34/M32/A/GRY	M32x1.5	15.8	41.0	44.2	26.7
AT34/M40/A/BLY	AT34/M40/A/GRY	M40x1.5	15.8	41.0	44.2	31.2
AT42/M40/A/BLY	AT42/M40/A/GRY	M40x1.5	15.8	50.8	54.2	34.0
AT42/M50/A/BLY	AT42/M50/A/GRY	M50x1.5	15.8	50.8	54.2	40.6
AT48/M50/A/BLY	AT48/M50/A/GRY	M50x1.5	15.8	52.1	65.0	44.0
AT54/M50/A/BLY	AT54/M50/A/GRY	M50x1.5	15.8	56.3	66.2	44.0
AT54/M63/A/BLY	AT54/M63/A/GRY	M63x1.5	15.8	56.3	66.2	52.0

Metric	Standard thread conforming to EN60423 & BS3643		
	Thread Size	Ext Thread Outside Diameter	Int Thread Inside Diameter
M16	16.0mm	14.4mm	1.5mm
M20	20.0mm	18.4mm	1.5mm
M25	25.0mm	23.4mm	1.5mm
M32	32.0mm	30.4mm	1.5mm
M40	40.0mm	38.4mm	1.5mm
M50	50.0mm	48.4mm	1.5mm
M63	63.0mm	61.4mm	1.5mm

NOTE: Dimensions are nominal

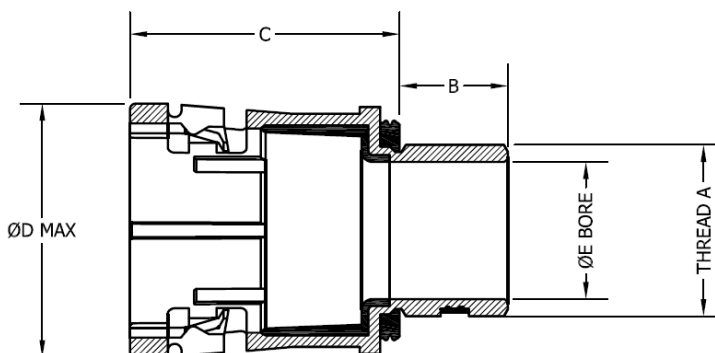
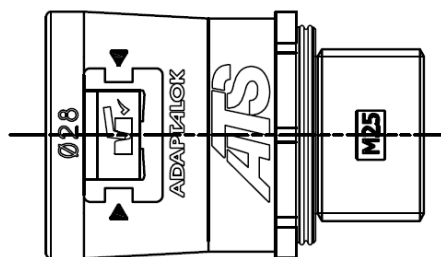

The Company's policy is one of continuous improvement and reserves the right to change specifications at any time without prior notice.

Non-Metallic Systems

ATS - Type A - Yellow Elastomer



Dimensional & Thread Data

Part No Black Body PF Threads	Part No Grey Body PF Threads	Thread A	Nominal Dimensions (mm)			
			B	C	D	E
AT13/PF038/A/BLY	AT13/PF038/A/GRY	PF $\frac{3}{8}$ "	11.5	34.2	21.2	11.2
AT16/PF038/A/BLY	AT16/PF038/A/GRY	PF $\frac{3}{8}$ "	11.5	36.0	23.2	11.2
AT16/PF050/A/BLY	AT16/PF050/A/GRY	PF $\frac{1}{2}$ "	13.0	36.0	23.2	15.2
AT21/PF050/A/BLY	AT21/PF050/A/GRY	PF $\frac{1}{2}$ "	13.0	36.5	30.2	15.2
AT28/PF075/A/BLY	AT28/PF075/A/GRY	PF $\frac{3}{4}$ "	15.0	39.3	37.2	20.0
AT34/PF100/A/BLY	AT34/PF100/A/GRY	PF1"	16.0	41.0	44.2	26.7
AT42/PF125/A/BLY	AT42/PF125/A/GRY	PF1 $\frac{1}{4}$ "	16.0	50.8	54.2	34.0
AT48/PF150/A/BLY	AT48/PF150/A/GRY	PF1 $\frac{1}{2}$ "	16.0	52.1	65.0	44.0
AT54/PF200/A/BLY	AT54/PF200/A/GRY	PF2"	15.8	56.3	66.2	44.0

PF	Japanese Standard thread conforming to JIS B 0202		
Thread Size	Ext Thread Outside Diameter	Int Thread Inside Diameter	Pitch
3/8"	16.7mm	15.0mm	1.34mm
1/2"	21.0mm	18.6mm	1.81mm
3/4"	26.4mm	24.1mm	1.81mm
1"	33.3mm	30.3mm	2.31mm
1 1/4"	41.9mm	39.0mm	2.31mm
1 1/2"	47.8mm	44.8mm	2.31mm
2"	59.6mm	56.7mm	2.31mm

NOTE: Dimensions are nominal

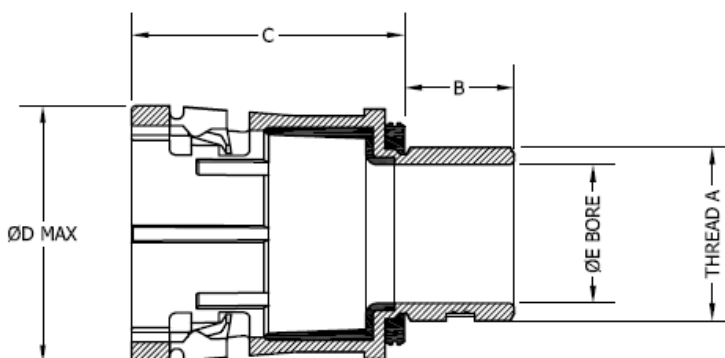
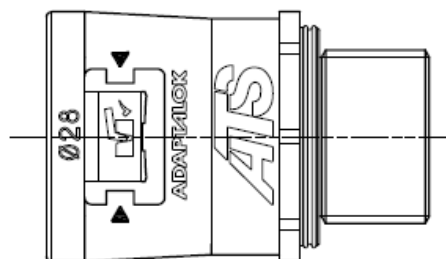

The Company's policy is one of continuous improvement and reserves the right to change specifications at any time without prior notice.

Non-Metallic Systems

ATS - Type A - Yellow Elastomer



Dimensional & Thread Data

Black Body Part No NPT Threads	Grey Body Part No NPT Threads	Thread A	Nominal Dimensions (mm)			
			B	C	D	E
AT13/038/A/BLY	AT13/038/A/GRY	NPT $\frac{3}{8}$	11.8	34.2	21.2	11.2
AT16/038/A/BLY	AT16/038/A/GRY	NPT $\frac{3}{8}$	11.8	36.0	23.2	11.2
AT16/050/A/BLY	AT16/050/A/GRY	NPT $\frac{1}{2}$	11.8	36.0	23.2	15.2
AT21/050/A/BLY	AT21/050/A/GRY	NPT $\frac{1}{2}$	11.8	39.3	30.3	15.2
AT28/075/A/BLY	AT28/075/A/GRY	NPT $\frac{3}{4}$	15.8	39.3	37.2	20.0
AT34/100/A/BLY	AT34/100/A/GRY	NPT1	15.8	41.0	44.2	26.5
AT42/125/A/BLY	AT42/125/A/GRY	NPT $1\frac{1}{4}$	15.8	50.8	54.2	34.0
AT48/150/A/BLY	AT48/150/A/GRY	NPT $1\frac{1}{2}$	15.8	53.5	65.0	41.0
AT54/200/A/BLY	AT54/200/A/GRY	NPT2	15.8	56.3	66.2	52.0

NPT	US taper seal pipe thread conforming to ANSI/ASME B1.20.1-1983	
Thread Size	Ext Thread Outside Diameter	Pitch
3/8"	16.7	1.14mm
1/2"	21.0	1.81mm
3/4"	26.4	1.81mm
1"	33.3	2.21mm
1 1/4"	41.9	2.21mm
1 1/2"	47.8	2.21mm
2"	59.6	2.21mm

NOTE: Dimensions are nominal

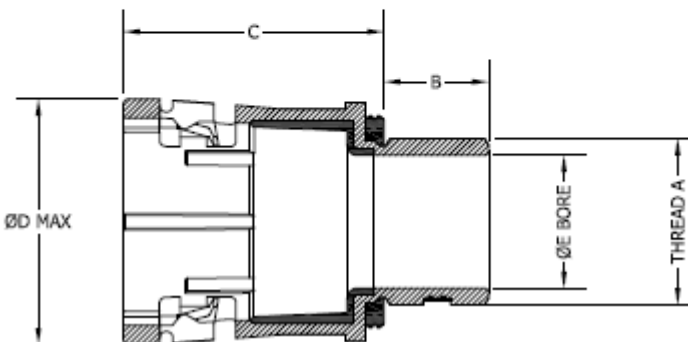
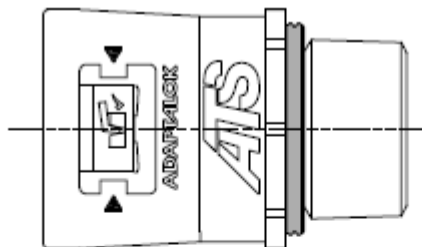

The Company's policy is one of continuous improvement and reserves the right to change specifications at any time without prior notice.

Non-Metallic Systems

ATS - Type A - Yellow Elastomer

ADAPTAFLIX



BS EN 61386 Classification

Fitting	Compression	Impact	Min temp	Max temp	bending	electrical	IP solids	IP water	Corrosion	Tensile	Non-flame Propogating	Suspended load
ATS	N/A	4	2	4	N/A	0	6	7	0	1	1	0

Mechanical Properties

Test Type	Methods / Standards	Requirements	Value
Tensile Strength	IEC61386-1	2 mins at Specified Value (<i>PAFS21 Conduit</i>)	Class 1
Tensile Strength		Ultimate Pullout (<i>PAFS21 Conduit</i>)	240N
Impact Strength @ -45°C	IEC61386-1	No visible damage	Class 1
Impact Strength @ -5°C	IEC61386-1	No visible damage	Class 3
Impact Strength @ 23°C	IEC61386-1	No visible damage	Class 5

Tensile Tests to IEC 61386 gives the minimum classification value only. Actual values will depend on the type and size of the fittings used and will always be greater than the minimum – Impact strength is the minimum classification value at the minimum temperature – actual values will depend on size and temperature. Specific values available on request.

Thermal Properties

Test Type	Methods / Standards	Requirements	Value
Dynamic Applications	IEC 61386-23	5000 Operations at MBR 2hrs	-45°C to +120°C
Static Short Term Temp		Temporary Use (3000hrs)	-50°C to +120°C
Static Long Term Temp		Permanent Use (30,000) Hours	-40°C to +105°C

The Company's policy is one of continuous improvement and reserves the right to change specifications at any time without prior notice.

Non-Metallic Systems

ATS - Type A - Yellow Elastomer



Flammability

Test Type	Method / Standard	Requirement	Result	Unit
Glow Wire	BS EN 60695-2-11	Extinguish within 30s	850°C	°C
Flammability	IEC 61386-1-12	1Kw Burner Flame to Self Extinguish	Pass	Pass/Fail
Oxygen Index - Nylon Body	ISO 4589-2		24.1	%
Ignition Rating - Nylon Body	NF F16-101	I Rating	I4	-
Oxygen Index - Elastomer Seal	ISO 4589-2		20.2	%
Ignition Rating - Elastomer Seal	ISO 4589-2	I Rating	I4	-

Smoke

Test Type	Method / Standard	Requirement	Result	Unit
Fume Rating - Nylon Body	NF F16-101	F Rating	F2	-
Fume Rating - Elastomer Seal	NF F16-101	F Rating	F2	-

Toxicity

Test Type	Method / Standard	Requirement	Result	Unit
Halogen Free	NFX 70-100	< 0.5%	Pass	Pass/Fail

Pre Test Conditions

Duration	Standard	Temperature	Relative Humidity
168 (Hours)	IEC61386	23 (°C)	50 (%)

Chemical Resistance Chart

Key:	Green	Yellow	Red	Black
Suitable :	●	●	●	●
Limited Suitability :	●	●	●	●
Unsuitable :	●	●	●	●
Not Tested :	●	●	●	●

● Astm No.1	● Diesel oil	● Methyl Bromide	● Sulphur Dioxide (Gas)
● Astm No.2	● Diethylamine	● MEK	● Sulphuric Acid (10%)
● Astm No.3	● Ethanol	● Nitric Acid (10%)	● Sulphuric Acid (70%)
● Acetic Acid (10%)	● Ether	● Nitric Acid (70%)	● Toluene
● Acetone	● Ethylamine	● Oxalic Acid	● Transformer Oil
● Aluminium Chloride	● Ethylene Glycol	● Ozone (Gas)	● 1,1,1-Trichloroethane
● Aniline	● Ethyl Ethanoate	● Paraffin oil	● Trichloroethylene
● Benzaldehyde	● Freon 32	● Petrol	● Turpentine
● Benzene	● Hydrochloric Acid (10%)	● Phenol	● Vegetable Oil
● Carbon tetrachloride	● Hydrochloric Acid (36%)	● Sea Water	● Vinyl Acetate
● Chlorine water	● Hydrogen Peroxide (35%)	● Silver Nitrate	● Water
● Chloroform	● Hydrogen Peroxide (87%)	● Skydrol	● White Spirit
● Citric Acid	● Lactic Acid	● Sodium Chloride	● Zinc Chloride
● Copper Sulphate	● Lubricating oil	● Sodium Hydroxide (10%)	
● Cresol	● Methanol	● Sodium Hydroxide (60%)	

All Values Based on Size 21 Fittings and PAFS Conduit, For Other Sizes and Conduit Systems Please Consult

The information above is given as a guide only and is based on published technical data and experience. The chemical resistance of the above products is dependant on factors such as chemical exposure, concentration of the chemical and temperature. The above chemicals are valid for a temperature of 23°C. Use of the above table is at the users own discretion and risk. Those using it must satisfy themselves that their application presents no health and safety risks. The end user should assess compatibility with their application and contact Thomas & Betts for further information.

ADHERENCE TO THE CURRENT WIRING REGULATIONS BS7671 OR NEC WIRING REGULATIONS (FOR USA) IS STRONGLY ADVISED.

MINIMUM BEND RADIUS FOR FLEXING IS DEPENDANT UPON MINIMUM TEMPERATURE, BENDING FREQUENCY AND CHEMICAL ENVIRONMENT.

The Company's policy is one of continuous improvement and reserves the right to change specifications at any time without prior notice.