

# Nylon Stopping Plug



## Features

- Suitable for use in Zones 1, 2, 21, 22

## Certification & Standards

<b>Approved to:</b>	EN/IEC 60079-0, 60079-7, 60079-31
<b>EC TYPE Examination Certificate:</b>	IMQ 13ATEX016X, IECEx IMQ 13.0005X
	Ex e IIC Gb
	Ex tb IIIC Db
	IP66-68
<b>Temperature:</b>	-40°C bis +80°C

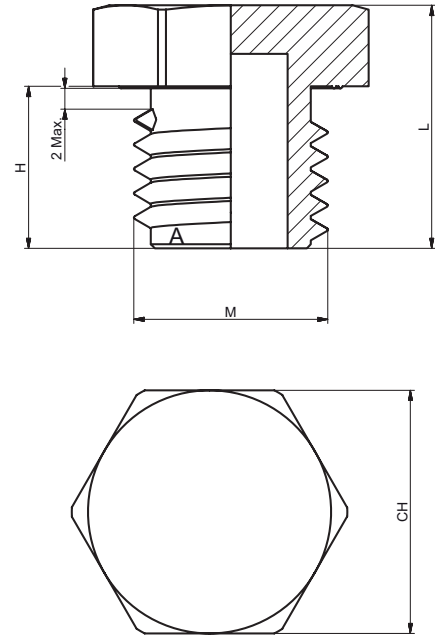
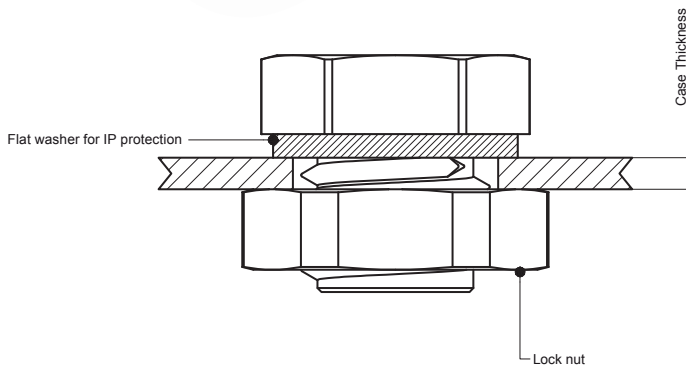

Nylon Type - Metric	Thread Size Metric (mm)	H	L	CH
EX-M12	12	8	15	15
EX-M16	16	10	15	19
EX-M20	20	10	15	23
EX-M25	25	10	15	28
EX-M32	32	15	20	36
EX-M40	40	18	27	46
EX-M50	50	18	27	55
EX-M63	63	18	27	69