

# SACE FORMULA A1

Istruzioni di installazione FORMULA A1/I-II  
Installation instructions FORMULA A1/I-II  
Installationsanleitung FORMULA A1/I-II  
Instructions pour l'installation FORMULA A1/I-II  
Kullanma Kılavuzu FORMULA A1/I-II

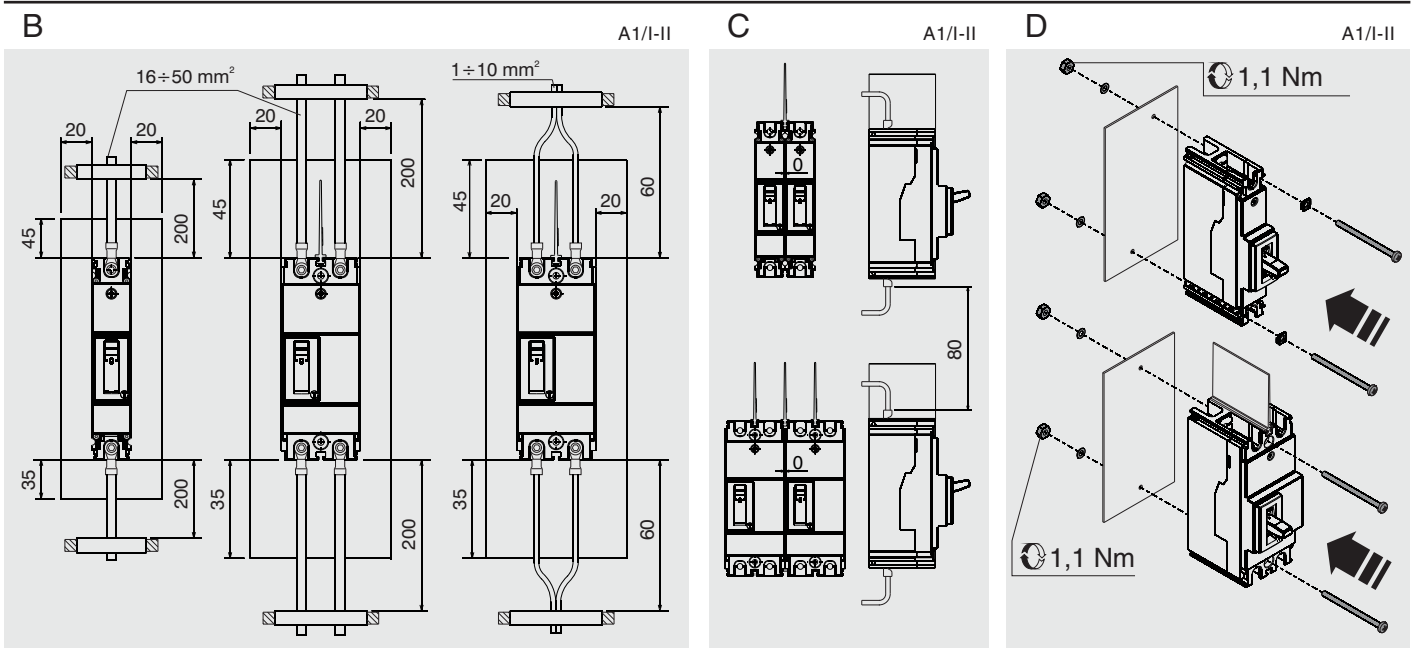
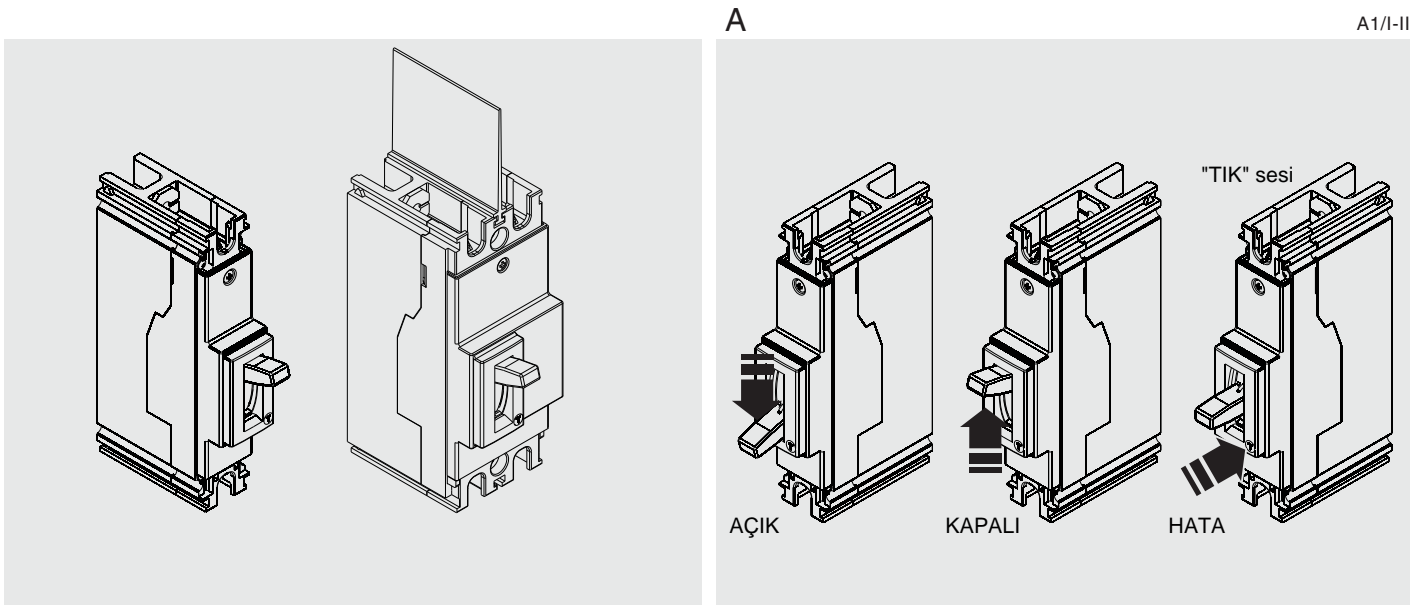

**E**

A1/I-II

**F**

A1/I-II

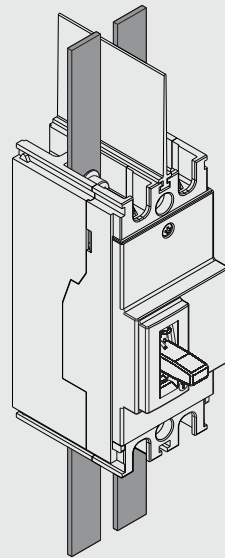
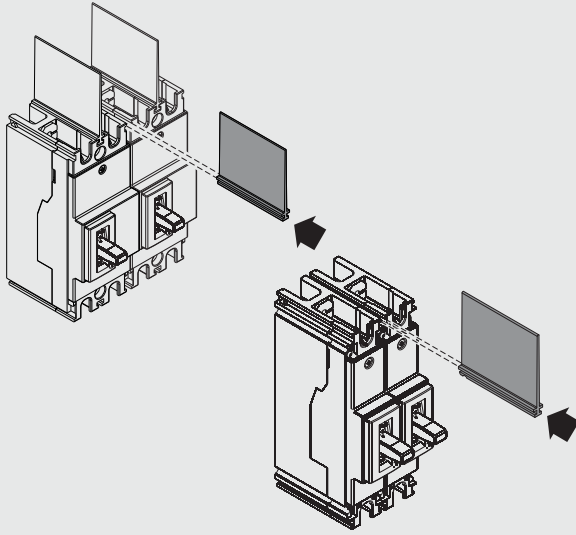

Usare cavi e capocorda isolati o barre isolate/ o eseguire prove di tipo specifiche sull' installazione.

Use insulated cables and wire terminals or insulated busbars/ or perform specific type tests on the installation.

Isolierte Kabel und Kabelschuhe oder isolierte Sammelschienen verwenden / oder spezifische Typprüfungen auf der Installation durchführen.

Utiliser des câbles et des cosses isolées ou des barres isolées / ou réaliser un test de type spécifique sur l'installation.

Utilizar cables y terminales aislados o barras aisladas / o efectuar pruebas de tipo específicas en la instalacion.

Kablo ve iletken terminalleri veya izole bara kullan veya yeni montajlı tip için tip test yaptır.

**G**

A1/I-II/F

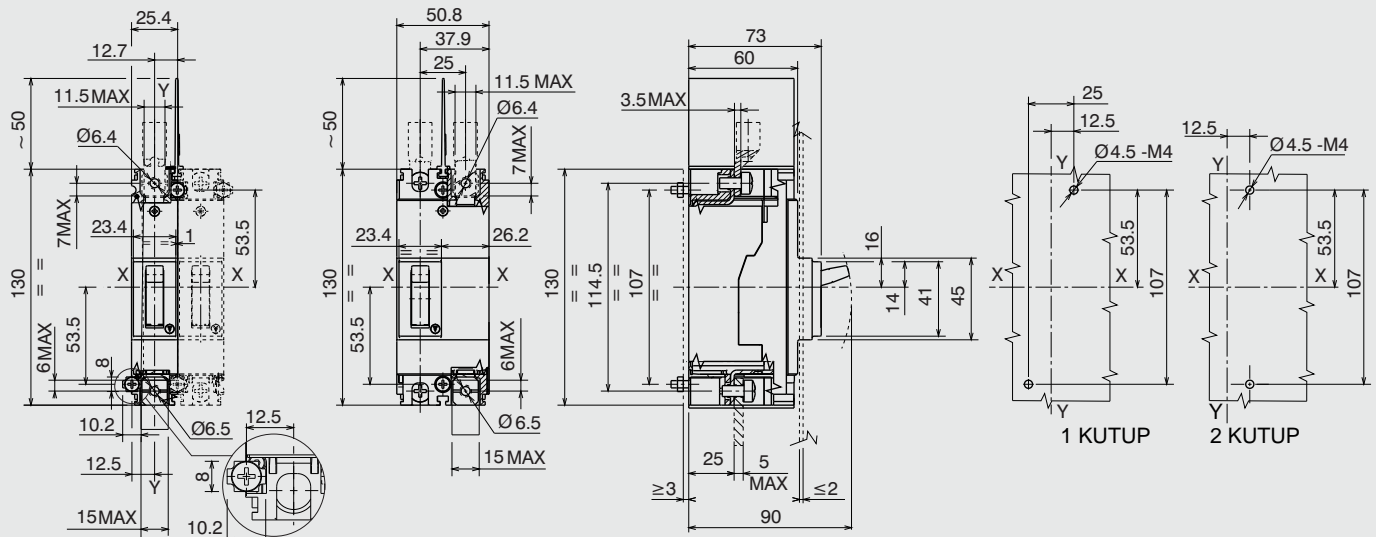
**H**

A1/I-II/EF

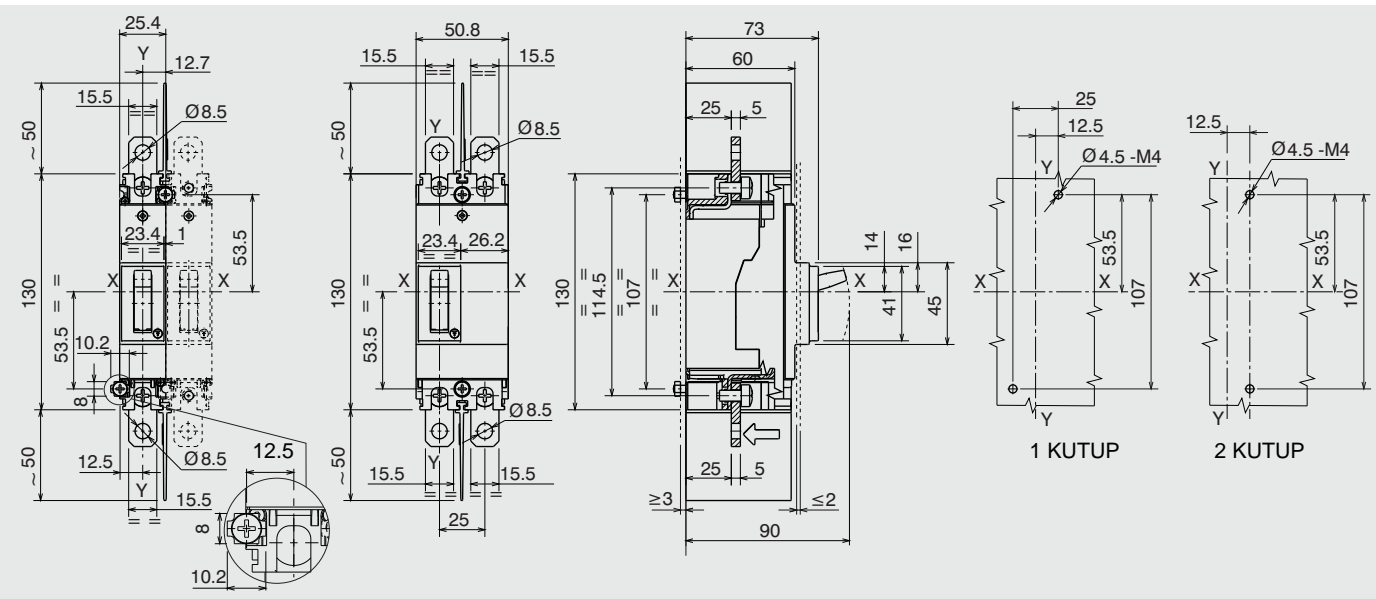



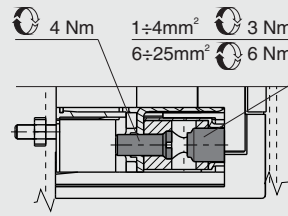
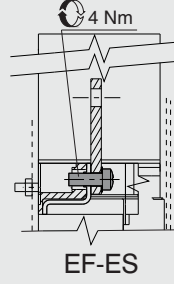
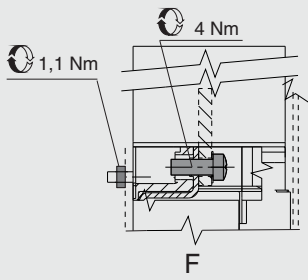

FcCuAl 25mm<sup>2</sup>

	mm <sup>2</sup>	mm <sup>2</sup>
25 mm <sup>2</sup> MIN	1	2,5
25 mm <sup>2</sup> MAX	25	25
50 mm <sup>2</sup> MIN	25	25
50 mm <sup>2</sup> MAX	50	50

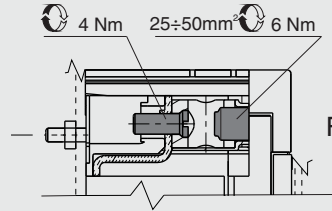
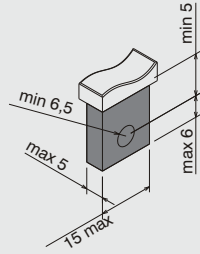
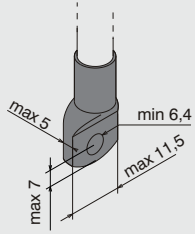

FcCuAl 50mm<sup>2</sup>