

LÅGSPÄNNINGSMOTORER

STATUS OCH
NYHETER

Högbo Bruk 4-5:e maj

Ledtider från fabriken i Vasa

Produkttyp	Ledtid Vasa	Tillgänglighet från lager	Kommentar
M3BP 71-315	~ 8 veckor	Ok	Normal
M3AA 160-250	~ 9 veckor	Ok	Normal

Produktutbud

Brett erbjudande för alla branscher och användningsområden

Processmotorer

- Induktionsmotorer
- Synkron reluktans
- PM-motorer
- Vattenkylda motorer
- Höga varvtal



Läs mer

"General performance"

- Induktionsmotorer för generell användning



Läs mer

Motors för explosionsfarliga miljöer

- Skydd mot dammexplosion typ Ex t
- Flamskydd typ Ex d, Ex de
- Utökad säkerhet Ex ec
- Motorer för gruvsdrift under jord



Läs mer

Motors för specifika branscher och användningsområden

- Bromsmotorer
- High dynamic performance motors
- Rullbordsmotorer
- Motorer för rökgasevakivering

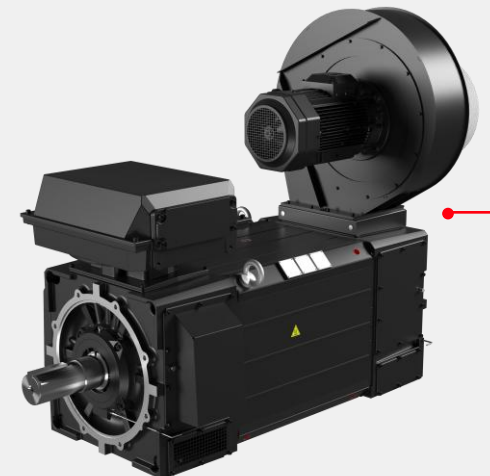

Motorer för generell användning

M2BAX

Översikt

- Lämplig för generell användning, när kunden efterfrågar en enklare (och billigare) motor än M3BP
- Snabb leverans direkt från lager
- Perfekt för återförsäljare
- Enkel och robust konstruktion
- Stort utbud av optioner och möjlighet till modifiering
- Ritningar etc finns på webben

M2BAX

- Uteffekt: 0.75–355 kW
- Axelstorlekar: IEC 71–355
- Poltal: 2, 4 & 6
- Verkningsgradsklass IE3 & IE4
- Termistorer
- B3, B5, B14, B34, B35





År 2025 lanserades
den första
induktionsmotorn
som uppfyller
energiklass **IE5**

M3BP 280-500 IE5: 75 – 1 300 kW, 2-6 pol

Vårt mest energieffektiva val för att driva pumpar och fläktar

SynRM - Synkron ReluktansMotor

Varför byta till SynRM ?

Bästa och energieffektivaste motorvalet för varvtalsstyrda drifter som pumpar, fläktar, kompressorer etc.

Utbytbar följer standard för byggmått (CENELEC och IEC) = kan enkelt ersätta induktionsmotorer.

Beprövad konstruktion – stomme, lager och lindning är identisk med ABB:s processmotor M3BP.

Robust **magnetfri** synkron reluktansrotor.

SynRM IE5 & IE6

Motortyp: M3BL

Tidigare: 5,5 - 315 kW, IE5

Nu:

Utökat effektområde: 0.75 – 450 kW

Axelhöjd: IEC 90 – 315

IE5: 0.75-90 kW

IE6: 110-450 kW

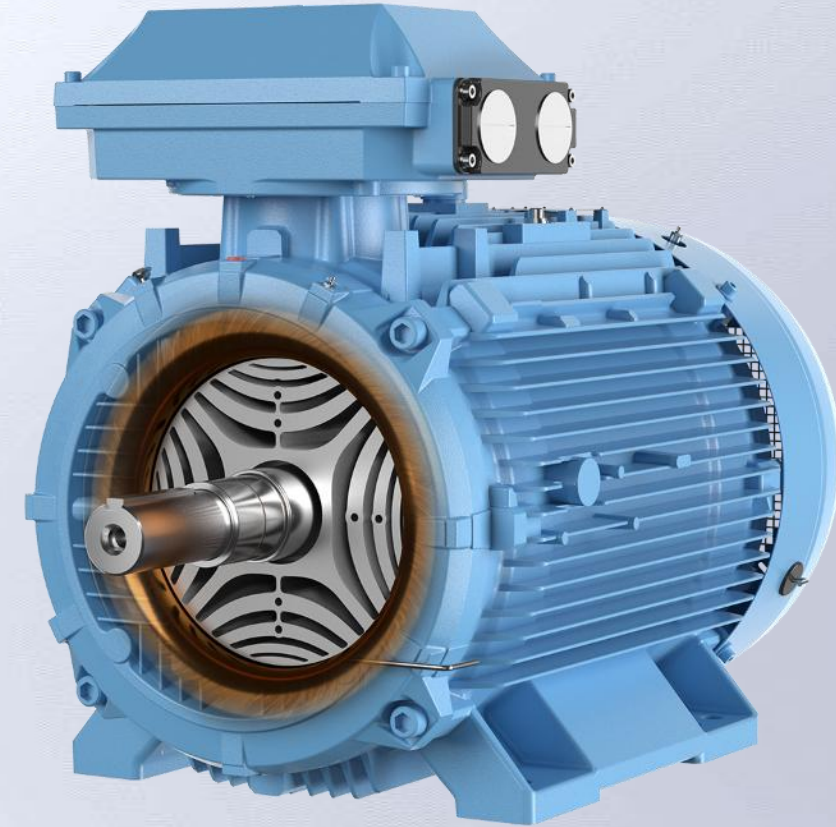

Synkrona reluktansmotorer- utökat utbud

Hög driftssäkerhet och verkningsgrad

SynRM IE5 & IE6



Specification

Output	0.75-450 kW
Shaft heights	IEC 90-315
Product line	M3BL
Efficiency	Up to IE6*

[Read more](#)

SynRM IE5 utökad säkerhet

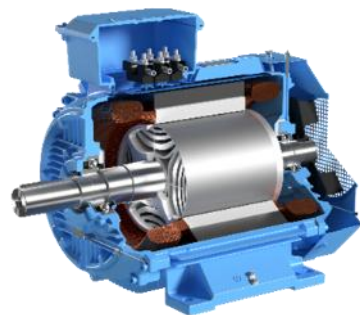

Specification

Output	5.5-315 kW
Shaft heights	IEC 132-315
Product line	M3HL/M3GL
Efficiency	IE5

[Read more](#)

SynRM vätskekyld



Specification

Output	37-710 kW
Shaft heights	IEC 200/ 250/280/315
Product line	M3LL
Efficiency	Up to IE5

[Read more](#)

SynRM vätskekyld kompakt



Specification

Output	90-240 kW
Shaft heights	IEC 200 / 250
Product line	M3LL
Efficiency	Up to IE4

[Read more](#)

SynRM kompakt



Specification

Output	17-350 kW
Shaft heights	IEC 160-315
Product line	M3BL
Efficiency	Up to IE4

[Read more](#)

PM-motorer som oppfyller energiklass IE5

Effektområdet 1.5 - 7.5 kW

PRODUCT NOTE

IE5 General performance cast iron permanent magnet motors

Ultra-premium efficiency and compact size



IE5 General performance permanent magnet motors compliment ABB premium product portfolio with its compact size and IE5 ultra premium efficiency performance. Excellent efficiency performance also with low load conditions provide high energy savings throughout the speed range.

Key features

General performance PM motors bring benefits with ultra-premium high efficiency combined with compact size

- 1 to 3 frame sizes more compact compared to standard induction motors
- Excellent partial load efficiency throughout the speed range
- Low frequency converter current demand
- Precise synchronous motor control
- Robust cast iron construction



IE5 M2BJX

Output	1.5 to 7.5 kW
Speed	3000/1500/1000
Motor type	M2BJX
Shaft heights	71-100
Frame material	Cast iron
Efficiency class	IE5
Network voltage	380-480 V, 50-60Hz
Motor supply	VSD, 365V
Mounting	B3, B5, B14, B34, B35
Ambient temperature	-20 °C - +40 °C
Cooling	IC411, TEFC
Protection	IP55 as standard
Certification	CE

Technical summary

LV Titanium Variable Speed Motors



Specification	ABB VSMs
Frame Size	71-160
Power rating	1.5-30kW
Frame material	Cast iron
Speed nominal/ max	1500 / 3000 / 4500 rpm
Input voltage	380-480 V (+10/-15%)
Nominal Frequency (output)	5-150 Hz
Frequency (input)	47-63Hz
Motor type	Permanent magnet (PM)
Efficiency class VSM (acc. To IEC 60034-30-2)	IE5
System efficiency class (IEC 68000-9-2)	IES 5
Ambient condition	-20°C ... +50°C, current rating is 90% of rated for ambient above 40C
Insulation/temperature rise	F/B
Altitude	1000m (upto 3000m with derating)
Minimum ingress protection class	IP55 (EN60529), IP56 and 65 as option
Cooling	TEBC, IC416
Allowed humidity	95%
Certification	CE
Control	Sensorless vector control
Communication and ports	Modbus RTU, 4 DI, 1DO, 2AI, 1 RO, +10V & +24V supply

ENERGIEFFEKTIVA MOTORER OCH SÄLJARGUMENTATION

Optimerad livscykelkostnad

En motor används under många år

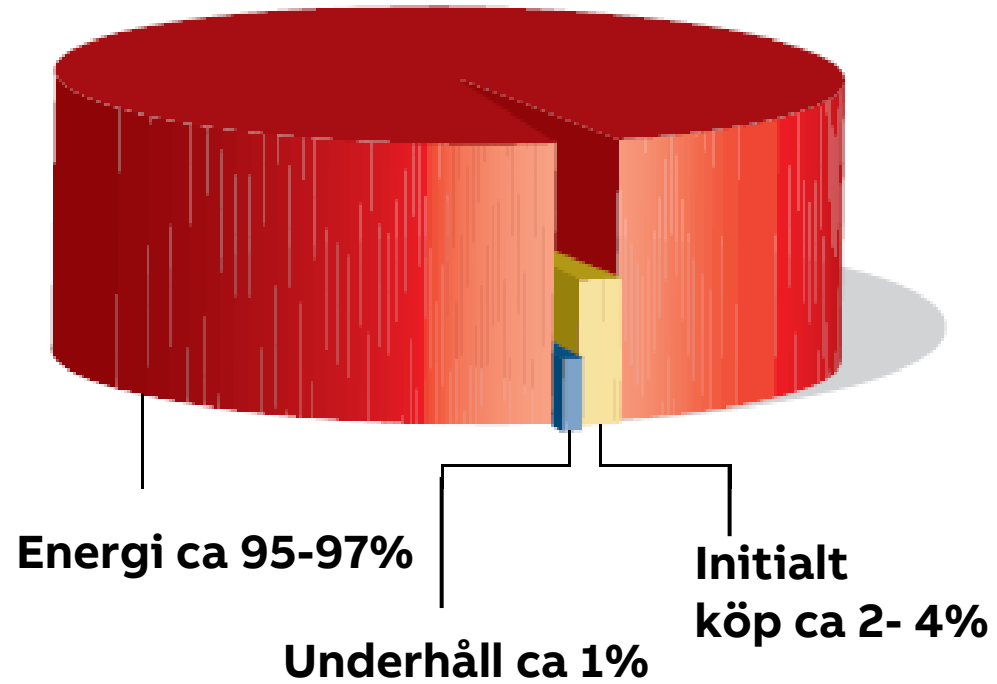

Vi hjälper våra kunder att optimera valet av motor och LCC

Exempel 250 kW DOL

Energibesparing vid 100% last 7/24:

3.75 kW x 8 760 tim = **32 850 kWh /år**

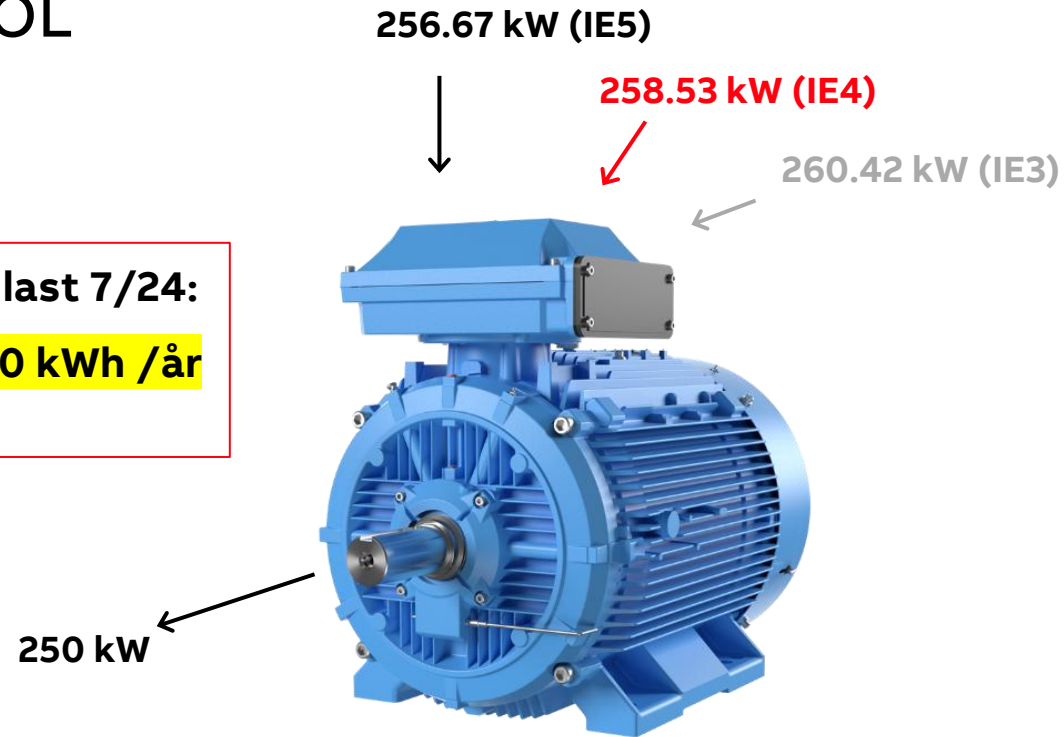

Ökning av verkningsgraden med 1,7 %-enheter minskar motorns förluster med 40% (från 10.42 till 6.67 kW)

● Förluster i IE5-motorn = 6.67 kW

Verkningsgrad = 97.4 %

Förlustreduktion vs IE3 = 3.75 kW

● Förluster i IE4-motorn = 8.53 kW

Verkningsgrad = 96.7%

Förlustreduktion vs IE3 = 1.89 kW

● Förluster IE3-motor = 10.42 kW

Verkningsgrad = 96.0% (IE3)

IE3 vs IE4

Cost of ownership Motor Comparison

M3BP 315LKC 4 - M3BP 315LKC 4

Type	Output	Efficiency class	Duty	Efficiency	Annual energy cost	Unit price
M3BP 315LKC 4	250 kW	IE4	DOL	96.7 %	1 310 445 SEK	279 000 SEK
M3BP 315LKC 4	250 kW	IE3	DOL	96 %	1 320 000 SEK	263 000 SEK

Economy	Environment		Energy		
Annual savings	9 555 SEK	Reduction of greenhouse gases		Reduction of energy consumption	
Payback period	20 Months	5 972 kg/year	≈ 0.9 cars	11 944 kWh/year	≈ 3.4 electric cars
Life cycle savings	191 107 SEK	119 442 kg/lifetime	≈ 17.1 cars	238 883 kWh/lifetime	≈ 68.3 electric cars

The calculations are based on these settings

Operating hours	24 hours/day	Operating days	330 days/year
Energy price	0.8 SEK/kWh	Currency	SEK
Service life	20 years	Maintenance cost	5%
Operating load	80%	Greenhouse gases	0.5/motor

IE3 vs IE5

Cost of ownership Motor Comparison

M3BP 315LKD 4 - M3BP 315LKC 4

Type	Output	Efficiency class	Duty	Efficiency	Annual energy cost	Unit price
M3BP 315LKD 4	250 kW	IE5	DOL	97.4 %	1 301 027 SEK	310 000 SEK
M3BP 315LKC 4	250 kW	IE3	DOL	96 %	1 320 000 SEK	263 000 SEK

Economy	Environment		Energy		
Annual savings	18 973 SEK	Reduction of greenhouse gases		Reduction of energy consumption	
Payback period	30 Months	11 858 kg/year	≈ 1.7 cars	23 717 kWh/year	≈ 6.8 electric cars
Life cycle savings	379 466 SEK	237 166 kg/lifetime	≈ 33.9 cars	474 333 kWh/lifetime	≈ 135.5 electric cars

The calculations are based on these settings

Operating hours	24 hours/day	Operating days	330 days/year
Energy price	0.8 SEK/kWh	Currency	SEK
Service life	20 years	Maintenance cost	5%
Operating load	80%	Greenhouse gases	0.5/motor

Styra varvtalet efter behov

Energieffektivt

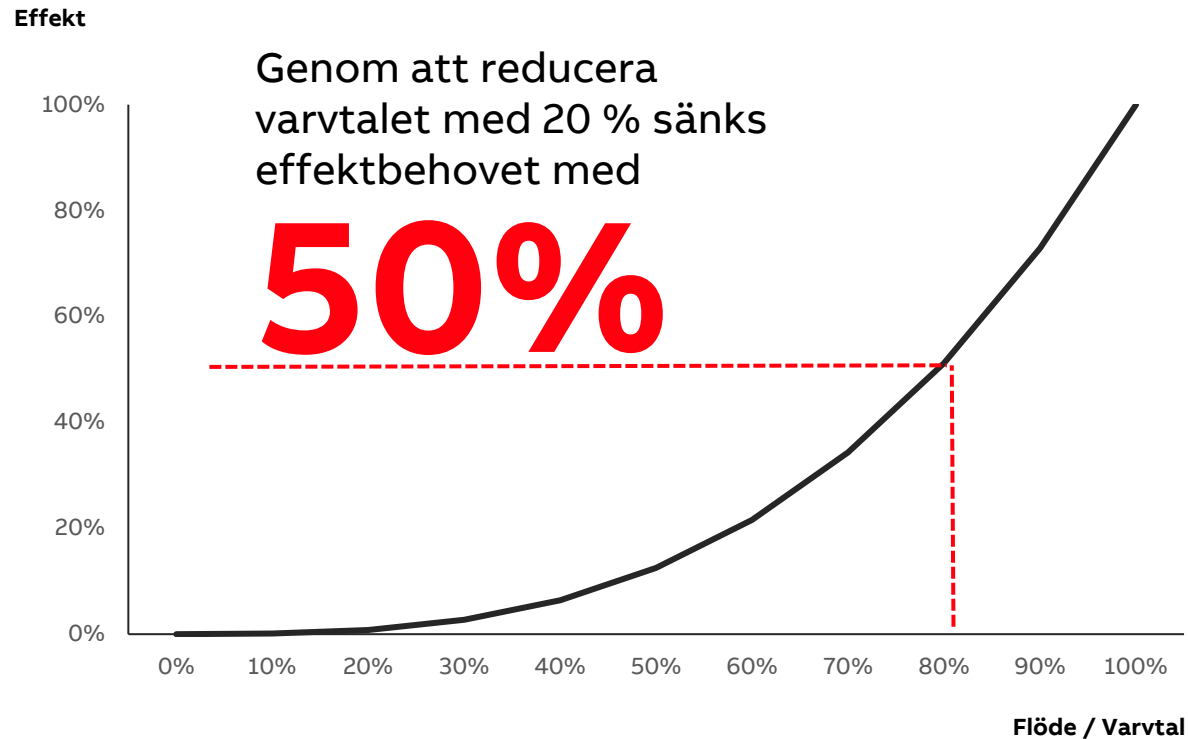

De flesta pumpar och fläktar är överdimensionerade och drivs på lägre last än nominellt.

Verkningsgraden gör skillnad - VSD

Induktion IE3, IE5 & SynRM IE6 256.67 kW

Energibesparing vid full drift:
5.66 kW x 8 760 tim = 49 581 kWh /år

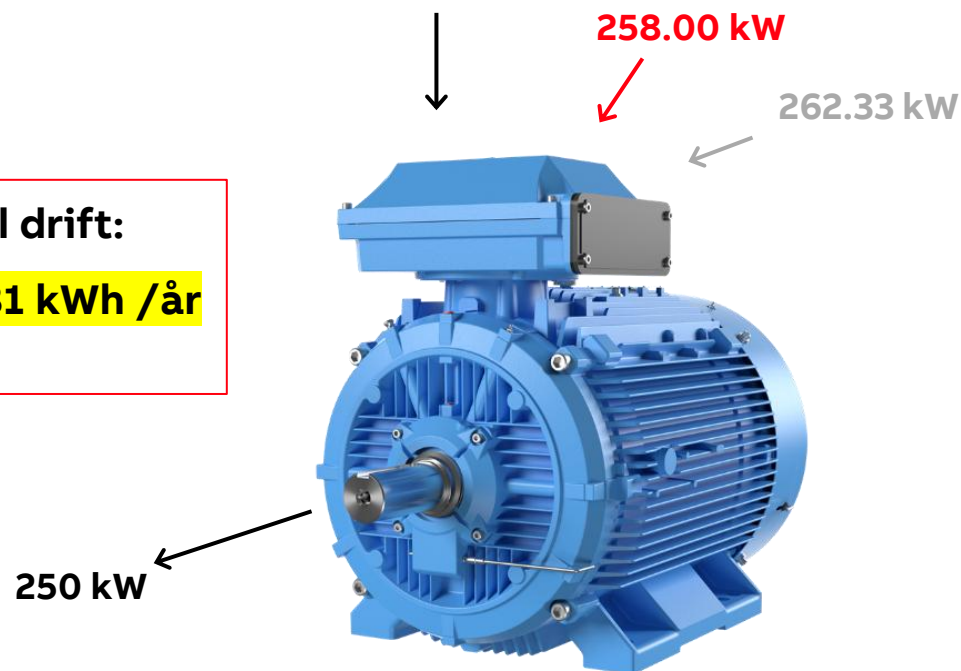

Ökning av verkningsgraden med 2,2 %-enheter minskar motorns förluster med 47% (från 12.6 till 6.67 kW)

- Förluster i IE6-motorn = 6.67 kW
Verkningsgrad = 97.4 %
Förlustreduktion vs IE3 = 5.66 kW

Verkningsgrad DOL: N/A

- Förluster i IE5-motorn = 8.00 kW
Verkningsgrad VSD = 96.9% (IE4)
Förlustreduktion vs IE3 = 4.33 kW

Verkningsgrad DOL = 97.4% (IE5)

- Förluster IE3-motor = 12.33 kW
Verkningsgrad VSD = 95.2% (IE2)

Verkningsgrad DOL = 96% IE3

IE3 vs IE6 250 kW VSD

Cost of ownership Motor Comparison

M3BL 315LKB 4 - M3BP 315LKC 4

Type	Output	Efficiency class	Duty	Efficiency	Annual energy cost	Unit price
M3BL 315LKB 4	250 kW	IE5	VSD	97.4 %	1 301 027 SEK	279 000 SEK
M3BP 315LKC 4	250 kW	IE3	VSD ¹	95.3 %	1 329 744 SEK	263 000 SEK

¹ DOL motor efficiency converted to motor efficiency with VSD supply when compared to a VSD motor

Economy	Environment		Energy		
Annual savings	28 717 SEK	Reduction of greenhouse gases		Reduction of energy consumption	
Payback period	7 Months	17 948 kg/year	≈ 2.6 cars	35 897 kWh/year	≈ 10.3 electric cars
Life cycle savings	574 348 SEK	358 967 kg/lifetime	≈ 51.3 cars	717 935 kWh/lifetime	≈ 205.1 electric cars

The calculations are based on these settings

Operating hours	24 hours/day	Operating days	330 days/year
Energy price	0.8 SEK/kWh	Currency	SEK
Service life	20 years	Maintenance cost	5%
Operating load	80%	Greenhouse gases	0.5/motor

Verkningsgraden gör skillnad – 7.5 KW VSD

Induktion IE3 vs IE4 vs SynRM IE5

Energibesparing vid full drift:

0,34 kW x 8 760 tim = **2 978 kWh /år**

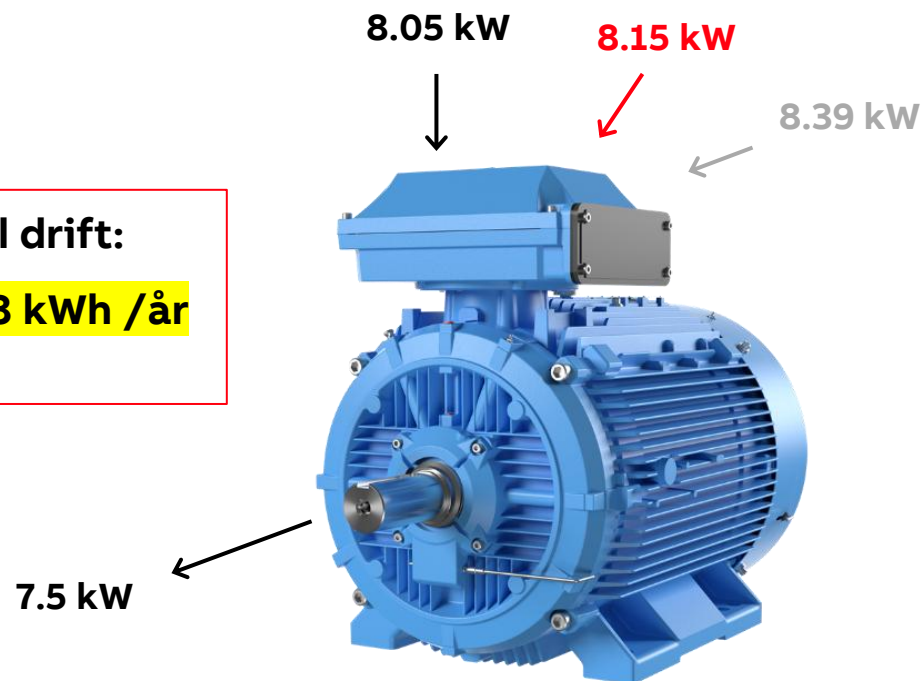

Ökning av verkningsgraden med 3,8 %-enheter minskar motorns förluster med 38.2% (från 0.89 till 0.55 kW)

- Förluster i IE5-motorn = 0.55 kW
Verkningsgrad VSD = 93.2 % VSD
Förlustreduktion vs IE3= 0.34 kW

Verkningsgrad DOL: N/A

- Förluster i IE4-motorn = 0.65 kW
Verkningsgrad VSD = 92.0% (IE3)
Förlustreduktion vs IE3 = 0.24 kW

Verkningsgrad DOL= 92.6% (IE4)

- Förluster IE3-motor = 0.89 kW
Verkningsgrad VSD = 89.4% (IE2)

Verkningsgrad DOL= 90.4% IE3

IE3 vs IE5 7.5 KW VSD

Cost of ownership Motor Comparison

M3BL 132SMB 4 - M3BP 132SMG 4

Type	Output	Efficiency class	Duty	Efficiency	Annual energy cost	Unit price
M3BL 132SMB 4	7.5 kW	IE5	VSD	93.2 %	40 790 SEK	14 700 SEK
M3BP 132SMG 4	7.5 kW	IE3	VSD ¹	89.4 %	42 545 SEK	11 100 SEK

¹ DOL motor efficiency converted to motor efficiency with VSD supply when compared to a VSD motor

Economy	Environment		Energy	
Annual savings	1 755 SEK	Reduction of greenhouse gases	Reduction of energy consumption	
Payback period	25 Months	1 097 kg/year	≈ 0.2 cars	2 194 kWh/year ≈ 0.6 electric cars
Life cycle savings	35 103 SEK	21 939 kg/lifetime	≈ 3.1 cars	43 879 kWh/lifetime ≈ 12.5 electric cars

The calculations are based on these settings

Operating hours	24 hours/day	Operating days	330 days/year
Energy price	0.8 SEK/kWh	Currency	SEK
Service life	20 years	Maintenance cost	5%
Operating load	80%	Greenhouse gases	0.5/motor

FRÅGOR?

AABB