

SLT900

Submersible transmitter for level measurement in liquids



Level transmitter with submersible probe in stainless steel for level measurement in vessels where pressure connection in the bottom of the vessel is not possible or desirable. For example pump pits, reservoirs or plastic tanks.

- SLT900 has microcomputer based electronics.
- HART communication.
- Accuracy 0,1 %.
- Configuration through HART communication from PC with the program DOX900 or with a standard hand held HART terminal.
- Withstands mediate temperatures up to 80 °C continuously.
- Well tested and approved for Exia according to ATEX and CE (EMC and PED).
- Lightning protected (option). Fullfills the demands for Class 1 testing according to IEC61643-1, 5 kA (10/350 uS). This means that the transmitter can withstand a stroke of lightning close to the supply/signal cables. (Not available together with EExia approval.)
- Stainless steel measurement probe with a rugged Hastelloy C 276 diaphragm (others on request).
- Embossed diaphragm, insensitive to particles and contact. Can easily be cleaned without deformation.
- Big span turn down ratio. Down to 1/30 of sensor limit.



Types and order codes:

The transmitters order codes for different configurations can be found from the table below.

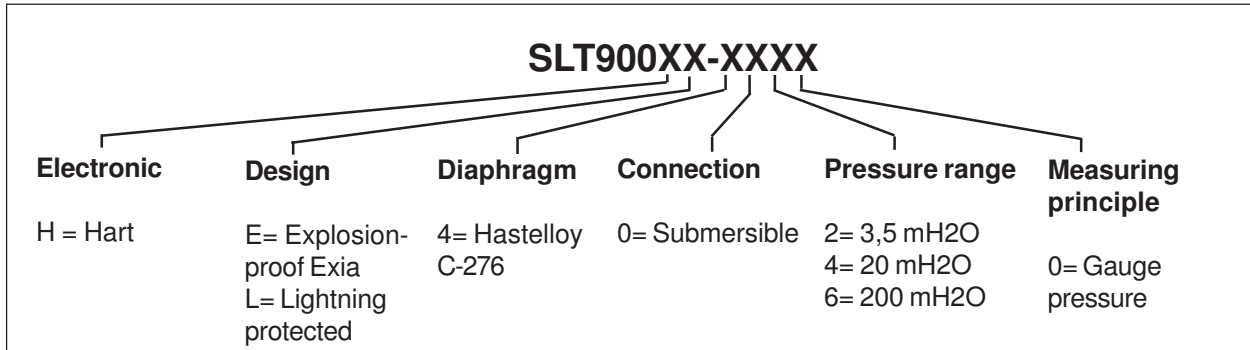

Ordering example

Lightning protected level transmitter with submersible measuring probe, 10 m cable and calibrated range 0-1,5 m water level will have the order code: **SLT900HL-4020** with calibrated range 0-1,5 mH2O

Description

SLT900 is a level transmitter for applications where pressure connection in the bottom of the vessel is not possible or desirable, for example pump pits. SLT900 consists of a measurement probe with the diameter 31 mm. The probe has a Hastelloy C-276 measuring diaphragm for highest corrosion resistance (other material as options). The diaphragm is also very insensitive to mechanical damage because of its design.

The probe are suspended in its connection cable. Standard length for the probe cable is 10 m. The cable is reinforced with a Kevlar cord and can be delivered in length up to 1000 m. For extremely corrosive media the cable can be delivered with teflon coating, max length 25 m. Connection of the probe cable can be done in a specially designed connection box. Its also possible to equip this box with a local display. (See next page for description.)

SLT900 can as an option be delivered with a good lightning protection (see next page for description).

SLT900 can as an option also be delivered in intrinsic safe design, Exia.

Function

SLT900 has a piezoresistive sensor connected to the media by means of a diaphragm and a capillary tube. The media pressure acts on the diaphragm

and is transferred to the sensor through a pressure intermediate oil. Since this oil completely fills the volume between the diaphragm and the sensor the diaphragm movement is very small when the pressure changes. Since the diaphragm are embossed to the surface underneath it is very insensitive to particles and contact. The capillary tube protects the sensor from high overloads because of short pressure shocks. To obtain atmospheric pressure on the back side of the sensor (for reference pressure) it is connected to the surrounding through a capillary tube inside the probe cable.

SLT900 has microcomputer-based electronics, which communicate with the outside world with 4 to 20 mA signal as well as HART communication. The electronics measure and convert the output signal from the pressure dependent sensor bridge to digital values. Furthermore, the total resistance of the sensor bridge is measured and these values are converted to digital temperature values. The electronics perform compensation for temperature drift of the sensor by means of compensation values entered at the factory calibration and at the same time the temperature measurement is also calibrated. Compensation for the non-linearity in the sensor is done in the same manner.

Different kinds of transfer functions, such as linear, square root, curves..., can be selected. The electronics perform the calculation for the selected transfer function and then the digital value is converted to analogue for the 4 to 20 mA current loop. The digital value can also be read via HART communication in optional engineering units, percentage or current.

SLT900 can be configured/calibrated fully by means of a hand terminal or a PC via HART communication.

To consider

Don't expose the diaphragm to unnecessary damage (even though its very robust and insensitive).

Don't descend the probe so that it stands on the bottom of the vessel.

Highest media temperature is +80°C.

Make sure that the vent tube is connected to the surrounding atmosphere without the risk for plugging.

If the media are turbulent or flowing fasten the probe appropriately.

Lightning protection

As an option SLT900 can be equipped with lightning protection. The transmitter will then have the code SLT900HL where L indicates "Lightning protected". This option can not be combined

with the intrinsic safe option (see below).

The lightning protection is built in at the factory. No external changes or external components are needed.

This option must be made to order, it can not be built in afterwards.

The protection is designed to withstand a lightning stroke close to the probe cable and connection cables but can not withstand a direct stroke. The protection is designed to meet the demands for Class 1 testing according to IEC61643-1 5 kA (10/350 uS).

This protection is normally enough in most applications. In specially exposed installations, where there is high risk for direct strokes, the protection ought to be reinforced.

The lightning protection is built up as a three step protection.

The pulse that enters the transmitter is caught by two varistors, three transient protection diodes and a double surge arrester.

The probe cables shield must be appropriately grounded for the protection to fulfill its purpose.

Intrinsic safety, Exia

SLT 900 can as an option be delivered in intrinsic safe design, Exia IIC T4, according to ATEX by NEMKO. The transmitter will then have the code SLT900HE where E indicates "Exia".

This option can not be combined with the lightning protected option (see above).

Connection and adjustment

Connection

The probe cables consists of 2 wires, shield and a vent tube. The wires is colour marked:

White	Signal/supply +
Brown	Signal/supply -
Shield	Ground
Vent tube	Atmosphere

On the Vent tube there is a Fluid filter mounted to prevent moisture to enter.

Connection box

A specially designed connection box can be delivered as an accessory. The box is equipped with cable glands and terminals for connection of the probe cable and the signal/supply cable. The box can also be equipped with a local display.

The box is equipped with an appropriate connection for the probe cables atmospheric vent tube. This connection does not affect the tightness of the box. Protection class IP67. The vent connection is design so that high pressure water from for example cleaners not can enter the vent or the box.

Display

The box can also be equipped with a local display. The display can show the the signal in optional engineering units, for example mWc or mH2O. Unit and limits is made to order.

The display is connected in series with the signal/supply cable and is feed by the current loop.

DOX900

DOX900 is a software tool on CD-ROM for Windows95/98/2000/XP and Windows NT for configuration, calibration and documentation.

DOX900 contains a database with available transmitter types. The program can configure transmitter specific values and perform maintenance, output signal and factory calibration. Furthermore, DOX900 performs copying of current configuration, backup on to hard disc, transmitting/

Adjustment

Adjustments can be done through HART communication. Connect the HART modem or a hand terminal over a 470 ohm (min 250 ohm) resistor. Use the program DOX900, a generic program or the HART hand held terminal for adjustments.

All parameters can be adjusted, for example span, zero, damping etc.

receiving via standard HART communication and a self-test with alarm functions.

Hand terminal

For parameter settings a hand terminal of HART type can be used.

Approvals

SLT900 is CE approved according to the EU directives for pressure equipment, PED, and EMC. SLT900HE is explosionproof approved, EEx ia IIC T4, by NEMKO (according to the EU directive ATEX).

The pressure intermediate oil is a FDA approved silicon oil.

The upper end of the probe (where the cable enters) is equipped with a R3/4" thread for connection of a pipe or a hanger.

Size

Probe size:

Diameter	31 mm
Length	250 mm

As standard the probe is delivered with a transportation diaphragm protection cover. This can also be used in normal operation if required.

Cable:

Length (standard)	10 m
(option up to)	1000 m
Diameter	6,5 mm
Area	0,75 mm ²
Vent tube (diam.)	2,3 mm
Reinforced with a Kevlar cord.	

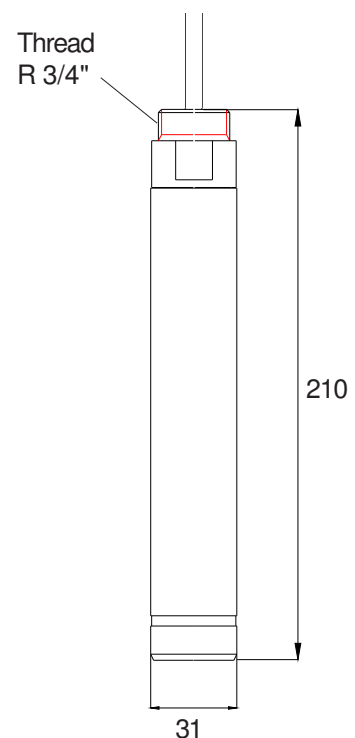

Technical specification SLT900:

Type:	Electronic submersible level transmitter with microcomputer based electronics	Series resistance:	$R_{kohm} = (Supply\ voltage - 11)/20$. For HART communication min 250 ohm
Function:	Directly connected transmitter with piezoresistive sensor	Series resistance dependance:	Better than +/- 0,1%
Operating range:	From -100% to 100% of upper sensorlimit	Supply voltage dependance:	Better than +/- 0,1%
Span:	Adjustable between upper sensor limit and 1/30 of this.	Temperature dependance:	Better than +/- 0,1% of max range. (From -10 to +70 degrees C.)
Zero:	Adjustable between -100% and 100% of upper sensor limit	Long time stability:	Better than 0,08 % per year.
Overload:	3,5 mH2O: Max 25mH2O	Vibration dependance:	
	20 mH2O: Max 60 mH2O	Perpendicular to the diaphragm:	Max +0,3 kPa/G
	200 mH2O: Max 600 mH2O	Parallell to the diaphragm:	Max +0,02 kPa/G
Material:	Diaphragm: Hastelloy C-276 (certain coatings on request)	Repeatability:	Better than +/- 0,1% of max range.
	Other media touched parts: Stainless steel SS2353	Accuracy:	Better than +/- 0,1% of max range (including nonlinearity, hysteresis and repeatability).
	Cable: Polyurethane	Electrical connection:	Lose wires
Ambient temperature:	-20 to +80 degrees C	Wire area:	0,75 mm ²
Damping:	0,1-10 sec. At delivery 1 sec	Encapsulation:	IP68
Media temperature:	Max 80 degrees C	Electrical safety:	According to EN 60204-1
Output:	4-20 mA, two wire connection, signal proportional to the pressure. Max current at overload 22,5 mA. HART communication	EMC:	According to EN 61326-1-2-3
Supply:	9-55 V DC	Intrinsic safety (option):	EExia IIC T4 (NEMKO) according to ATEX
Filling liquid:	AK100, food approved siliconoil (FDA approval)	PED:	According to 97/23/EG
Weight:	700 g including 10 m cable.	Lightning protection (option):	Class 1 testing according to IEC61643-1. 5kA (10/350 uS).



ABB Measurements & Analytics
 Phone: +46 10 732 04 50 (ask for Instrumentation)
 Address: Viderögatan 2, 164 40 KISTA

Internet: www.abb.se/instrumentation
 E-mail: se-instrumentation.sales@abb.com